

CRANE-National Vendors

DOCUMENT: 4740027

Pagination Guide

60 Lb. White

3 Holes

2 Staples

TOTAL COUNT: 53; 0 OVERSIZE ART

**AVOID MAKING MARKS ON THIS PAGINATION GUIDE.
PLEASE RETURN THIS GUIDE WITH ARTWORK!**

FRONT SIDES	BACK SIDES
Self Cover	2 of 19
3 of 19	4 of 19
5 of 19	6 of 19
7 of 19	8 of 19
9 of 19	10 of 19
11 of 19	12 of 19
13 of 19	14 of 19
15 of 19	16 of 19
17 of 19	18 of 19
19 of 19	1 of 34
2 of 34	3 of 34
4 of 34	5 of 34
6 of 34	7 of 34
8 of 34	9 of 34
10 of 34	11 of 34
12 of 34	13 of 34
14 of 34	15 of 34
16 of 34	17 of 34
18 of 34	19 of 34
20 of 34	21 of 34
22 of 34	23 of 34
24 of 34	25 of 34
26 of 34	27 of 34
28 of 34	29 of 34
30 of 34	31 of 34
32 of 34	33 of 34
34 of 34	Blank

KIT PART NUMBER 4747802 (U.S.) and 4747809 (U.S.)
KIT PART NUMBER 4777805 (U.K.) and 4777818 (U.K.)
KIT PART NUMBER 4777807 (GER./FR.) and 4777819 (GER./FR.)

**INSTRUCTIONS FOR INSTALLING A REFRIGERATED OR FROZEN FOOD MODULE
 IN A MODEL 474, 475, 476, 477, 478, OR 479 MERCHANDISER**



Read these instructions carefully before installing the kit.
 Retain these instructions for part numbers and for future reference.

Tables 1 thru 4 list parts for the kit you purchased. Determine if you have a refrigerated or frozen food kit and domestic (U.S.) or foreign application, then locate the table which lists the parts for your kit.

Table 1. Refrigerated Food Kit 4747802 (Domestic - U.S.)

PART NUMBER	DESCRIPTION	QTY
4747800	Refrigerated Food Module and Refrigeration Module Assembly - Domestic	1
4741213	Cover and Seal Assembly - Compressor	1
4740021	Plastic Bag Assembly - Refrig/Frz Food - Domestic	1
4747715	Bracket - Cabinet Support	2
4727144	Screw - #8-18 x .62, Hex Hd	8
1141046	Screw - #10-32 x 3/8, Acorn Hex Washer Head	2
4740016	Divider and Spiral Package	1
4407807	Divider and Spring Assembly	2
4407820	Spiral and Retainer - 6 Count/LH, Gm	1
4407823	Spiral and Retainer - 6 Count/RH, Gm	1

XEROX COPY

Table 2. Frozen Food Kit 4747809 (Domestic - U.S.)

PART NUMBER	DESCRIPTION	QTY
4747700	Frozen Food Module and Refrigeration Module Assembly - Domestic	1
4741213	Cover and Seal Assembly - Compressor	1
4740021	Plastic Bag Assembly - Refrig/Frz Food - Domestic	1
4747715	Bracket - Cabinet Support	1
4727144	Screw - #8-18 x .62, Hex Hd	8
1141046	Screw - #10-32 x 3/8, Acorn Hex Washer Head	2
4740016	Divider and Spiral Package	1
4407807	Divider and Spring Assembly	2
4407820	Spiral and Retainer - 6 Count/LH, Gm	1
4407823	Spiral and Retainer - 6 Count/RH, Gm	1
4747714	Bracket and Clamp Assembly - Cabinet Support	1
1211141	Switch - 2DM4	1
1451087	Screw - #8-32 x .31, Hex Hd, T/F	2
2342315	Retainer - Harness	2
4042121	Wire Tie - Self-Clinching	2
4741212	Harness - Glass Heater - Domestic	1

Table 3. Refrigerated Food Kit 4777805/4777807 (Foreign - U.K./GER./FR.)

PART NUMBER	DESCRIPTION	QTY
4777806	Refrigerated Food Module and Refrigeration Module Assembly - Foreign	1
4741213	Cover and Seal Assembly - Compressor	1
4770025	Plastic Bag Assembly - Refrig/Frz Food - UK	1
4770027	Plastic Bag Assembly - Refrig/Frz Food - GER/FR	1
4407001	Bracket - Cabinet Support	2
4727144	Screw - #8-18 x .62, Hex Hd	8
1141046	Screw - #10-32 x 3/8, Acorn Hex Washer Head	2
4740016	Divider and Spiral Package	1
4407807	Divider and Spring Assembly	2
4407820	Spiral and Retainer - 6 Count/LH, Gm	1
4407823	Spiral and Retainer - 6 Count/RH, Gm	1

Table 4. Frozen Food Kit 4777818/4777819 (Foreign - U.K./GER./FR.)

PART NUMBER	DESCRIPTION	QTY
4777804	Frozen Food Module and Refrigeration Module Assembly - Foreign	1
4741213	Cover and Seal Assembly - Compressor	1
4770025	Plastic Bag Assembly - Refrig/Frz Food - UK	1
4770027	Plastic Bag Assembly - Refrig/Frz Food - GER/FR	1
4747715	Bracket - Cabinet Support	1
4727144	Screw - #8-18 x .62, Hex Hd	8
1141048	Screw - #10-32 x 3/8, Acorn Hex Washer Head	2
4740016	Divider and Spiral Package	1
4407807	Divider and Spring Assembly	2
4407820	Spiral and Retainer - 6 Count/LH, Grn	1
4407822	Spiral and Retainer - 6 Count/RH, Grn	1
4747714	Bracket and Clamp Assembly - Cabinet Support	1
2342315	Retainer - Harness	2
4042121	Wire Tie - Self-Clinching	2
4741225	Harness - Glass Heater - Foreign	1

PERFORM THE FOLLOWING STEPS TO INSTALL A REFRIGERATED FOOD MODULE IN THE MERCHANDISER:

1. Remove all packaging materials from the kit.

WARNING
To prevent personnel injury or death, disconnect power from the merchandiser while performing these procedures.

2. Remove the bottom tray from the merchandiser. Refer to paragraph S-3 in the Mechanical Set-Up, Operation and Maintenance Manual.

CAUTION
Damage may occur to the food module or the merchandiser if there is not proper clearance between the food module door and delivery pan. Before operating the merchandiser, be sure you have adjusted the food module for clearance.

Refer to Figure 1 during the following step:

3. Adjust the the food module door by turning the hex head screws on the bottom of the refrigeration housing front legs. The distance between the lower right and left corners of the food module door and the floor is 17-3/4IN to 18IN. Turn these screws until this dimension is measured.

Refer to Figure 2 during the following procedure:

4. If you are installing the food module into a chilled snack machine, foreign, care must be taken to not damage the gaskets in the merchandiser. Apply talcum powder (baby powder or corn starch for example) around the duct openings in the refrigeration housing and to the surface of the foam gaskets in the machine. Apply talcum powder to the card stock mentioned in the following steps.

5. If your merchandiser has round gaskets on the right side, cut one piece of thin card stock (file folder thickness) approximately 8-1/2 x 30 inches long. Place this piece over the gaskets and tape the front edge of the card stock to the merchandiser side. The card stock will compress the gaskets as the food module is installed.

6. Cut a second piece of card stock 8-1/2 x 12 inches. Tape this piece over the front of the square gasket which is on the left of the merchandiser. Once the food module is fully inserted into the merchandiser, step 9, the card stock can be removed.

CAUTION

At least two people are required to move the food module because of its weight. Exercise caution to prevent personnel injury.

Refer to Figure 3 during the following procedure:

7. Two people will be required to lift and slide the food module partially into the merchandiser cabinet. The card stock should prevent the food module from catching the edges of the gaskets and damaging them.

8. Connect the harnesses as shown in Figure 4.

Refer to Figure 5 during the following procedure:

9. Slide the food module fully into the merchandiser cabinet. Pull out the pieces of card stock. There are two holes in the merchandiser floor on the right side. The slotted hole on the right side of the refrigeration mounting pan should line up with the rear hole. See Detail B, Figure 5.

10. Check the food module door and delivery pan clearance per step 3 and adjust if necessary.

11. Install one screw (1141046) in the refrigeration mounting pan on the right side.

12. Using a #19 drill bit, drill one hole in the merchandiser floor using the slotted hole in the left side of the refrigeration mounting pan as a guide. See Detail B, Figure 5. 475/476/478/479 models only.

13. Secure the refrigeration module to the merchandiser floor using another screw (1141046).

Refer to Figure 5, Detail A during the following procedure:

14. Mount the cabinet support brackets on the top of the food module housing on the right and left sides using two screws (4727144) per bracket. Make sure the brackets are outside the tray rails.

Refer to Figure 6 during the following procedure:

15. Install the refrigeration assembly cover and secure in place using four screws (4727144).

16. Install the tray removed in step 2 and restore power to the merchandiser.

CAUTION

Damage may occur to the food module or the merchandiser if proper clearance between food module door and delivery pan is not adjusted. Before operating the merchandiser, be sure you have adjusted the food module door clearance.

17. See the Food Module Supplement P/N 1470052, in the Mechanical Set-Up, Operation and Maintenance Manual P/N 1470058, for food module set-up procedures.

18. See the Food Module Programming Supplement P/N 1470053, in the Programming Guide P/N 1470059, for programming procedures for the food module.

PERFORM THE FOLLOWING STEPS TO INSTALL A FROZEN FOOD MODULE IN THE MERCHANDISER:

1. Remove all packaging materials from the kit.

WARNING

To prevent personnel injury or death, disconnect power from the merchandiser while performing these procedures.

2. Remove the bottom tray from the merchandiser. Refer to paragraph S-3 in the Mechanical Set-Up, Operation and Maintenance Manual.

Refer to Figure 7 while performing the following step.

3. Install one harness retainer on the left side of the cabinet below the bottom tray rail and secure with one screw (1451097).

4. Install one harness retainer on the left rear channel of the merchandiser cabinet and secure with one screw (1451097). (U.S. merchandisers only)

Refer to Figure 8, Sheet 1 while performing the following step.

5. Install the door heater harness and interlock switch.

6. Repeat steps 8 thru 14 of the refrigerated food installation procedures.

Refer to Figure 8, Sheet 1 while performing steps 7 and 8.

7. Route the door heater cable through the harness retainer you installed on the left side of the merchandiser cabinet and through the harness retainers on the left cabinet support bracket assembly.

8. Connect the door heater cable (J177) to the merchandiser door switch cable (J177).

Refer to Figure 8, Sheet 2 while performing the following step.

9. On merchandisers located outside the U.S. (U.K./GER./FR.), route the door heater cable through the harness retainer you installed on the left side of the merchandiser cabinet, through the harness retainers on the left cabinet support bracket assembly, then down to the refrigeration assembly connector (J176).

10. Repeat Steps 15 thru 18 of the refrigerated food installation procedures.

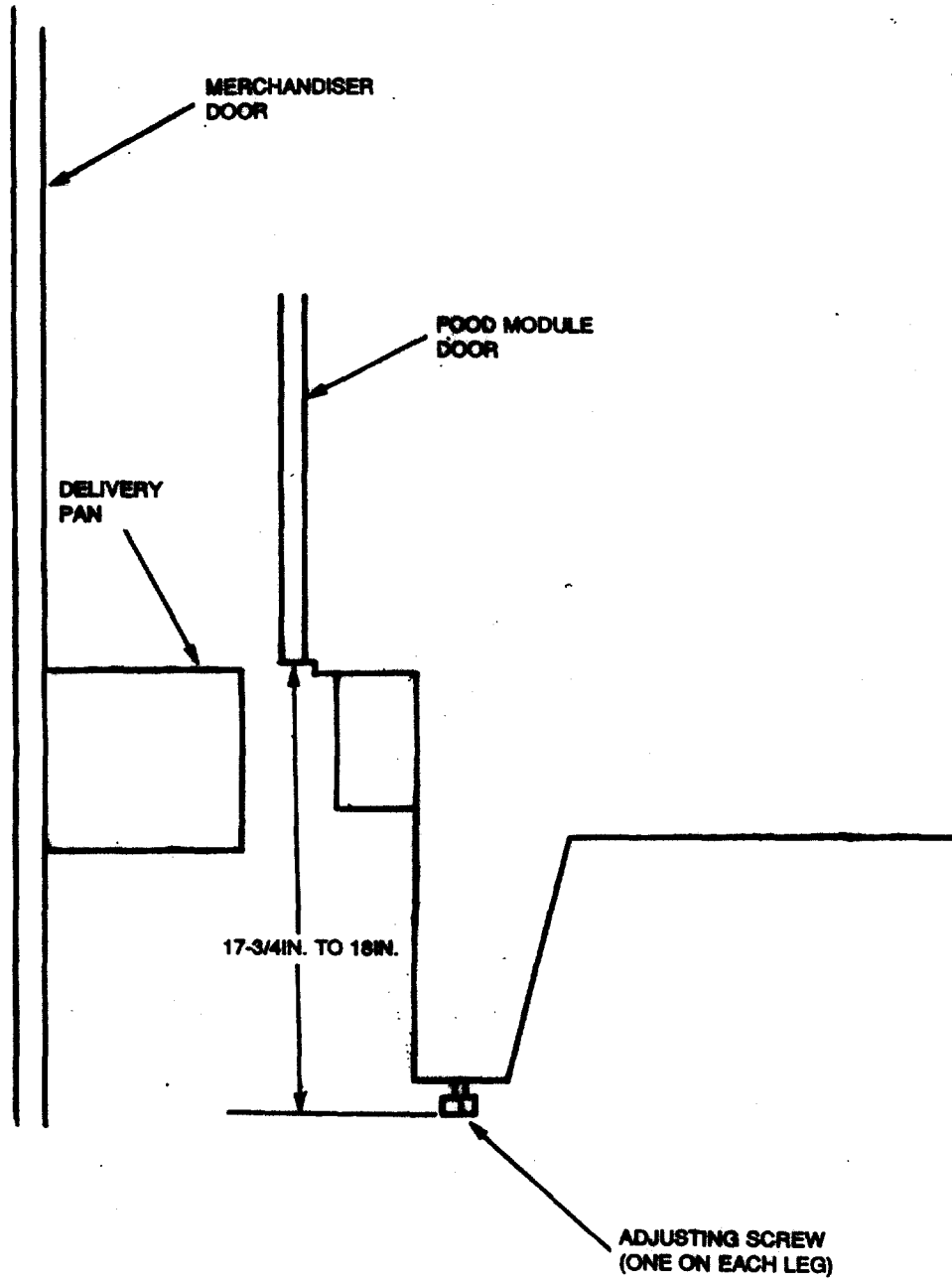

FIGURE 1.

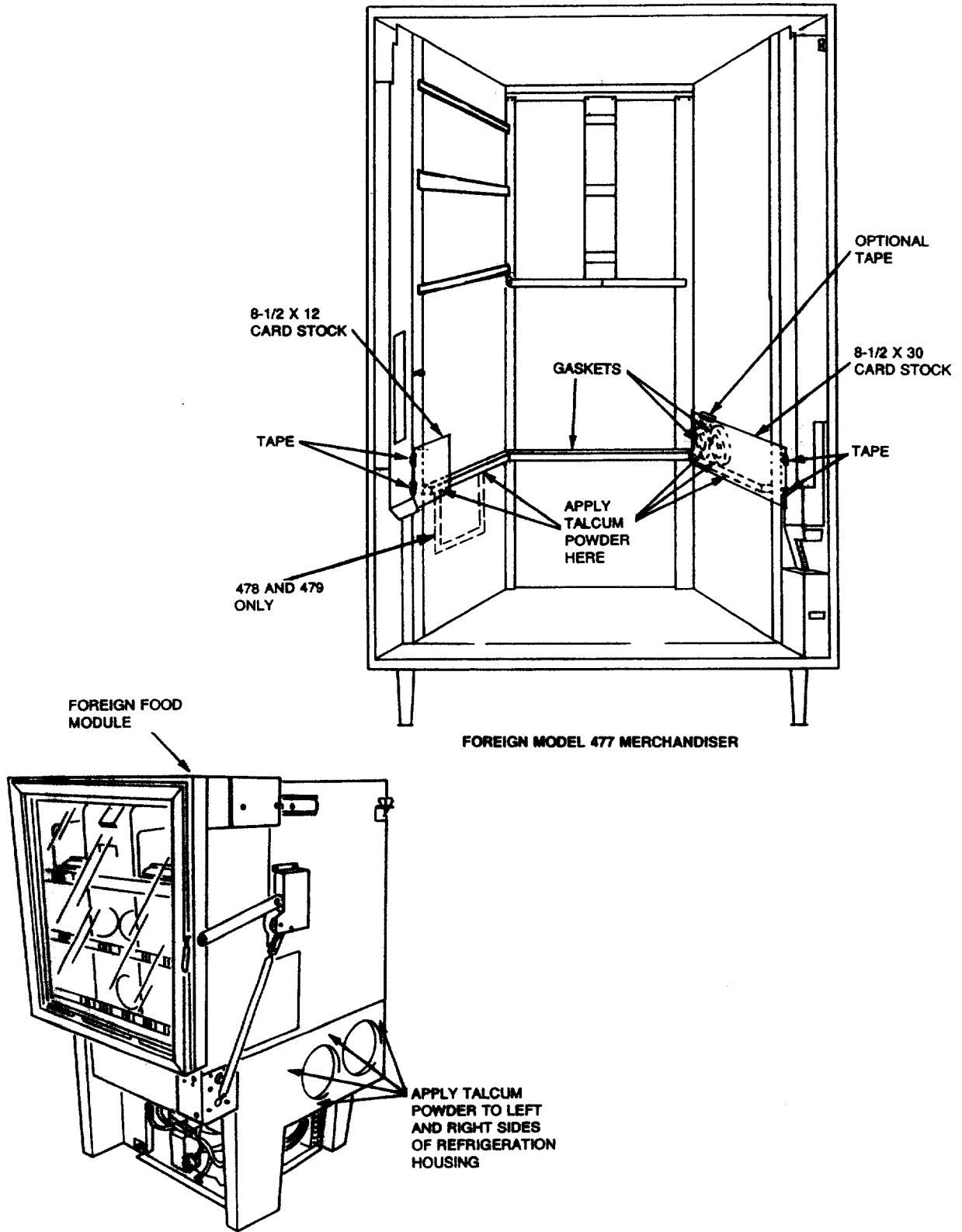
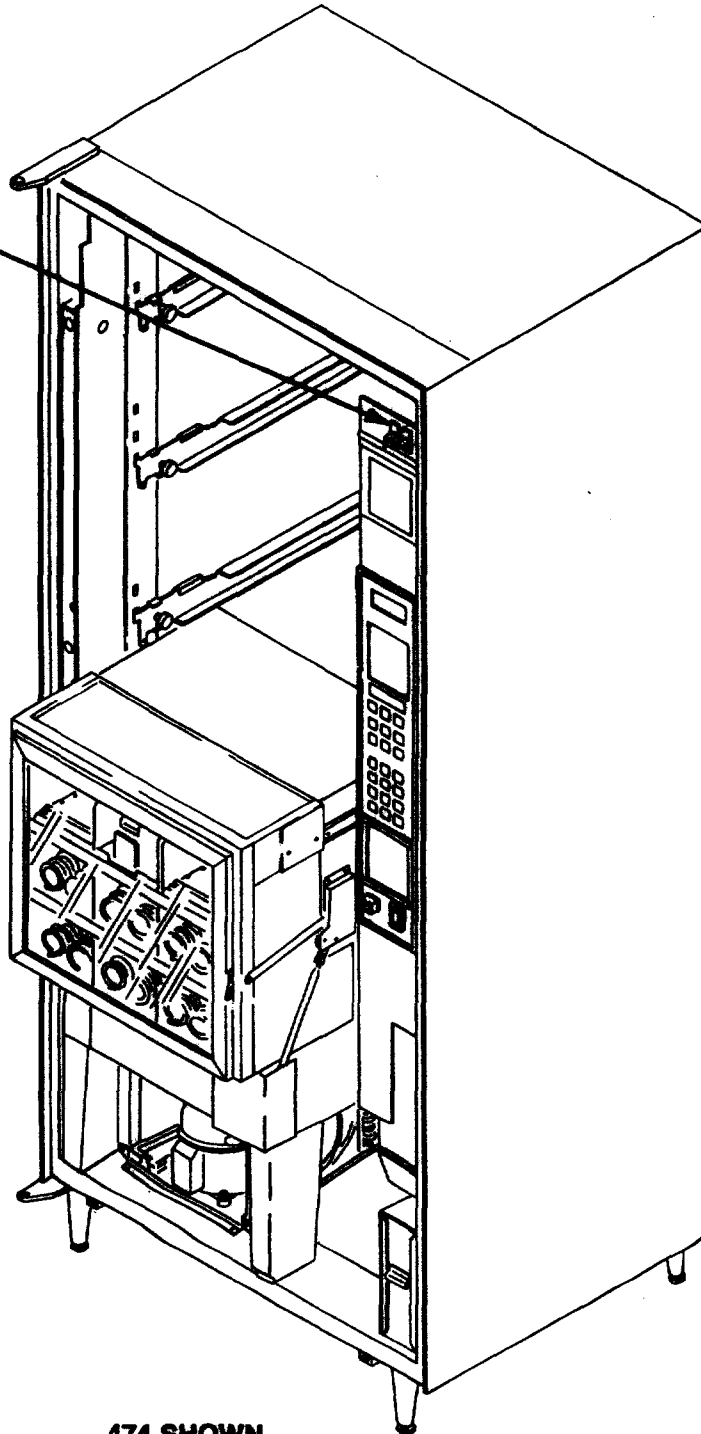

FIGURE 2.

**INTERLOCK
SWITCH
(DOMESTIC FROZEN
FOOD MERCHANDISERS
ONLY)**

**FOOD MODULE
SHOWN PARTIALLY
INSTALLED**



474 SHOWN

FIGURE 3.

475/476/478/479 MODELS

**FOOD MODULE
DOOR-TO-COMPRESSOR
HARNESS ROUTING FOR
475/476/478/479 ONLY**

**J162 4-PIN
CONNECTOR MATES
WITH J162 ON
CONTROL SWITCH
HARNESS (SEE
SHEET 2)**

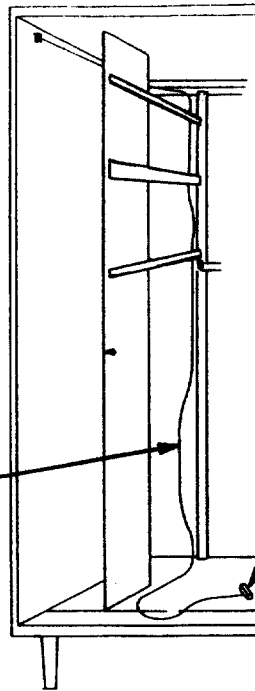

**1471183
6-TRAY CABINET
HARNESS**

**J49 12-PIN
CONNECTOR
MATES WITH
J49 ON FOOD
MODULE (SEE
SHEET 2)**

**J90 4-PIN
CONNECTOR
MATES WITH
J90 ON FOOD
MODULE PCB
(SEE SHEET 2)**

**J162 4-PIN
CONNECTOR MATES
WITH J162 ON
CONTROL SWITCH
HARNESS (SEE
SHEET 2)**

TO DELIVERY PAN

CONTROLLER

**4401020
FOOD MODULE
TEMPERATURE
SENSOR HARNESS**

POWER PANEL

**4401030
FOOD MODULE
TRAY JUMPER
HARNESS**

**J31 12-PIN
INLINE CONNECTOR
MATES WITH J31 ON
FOOD MODULE PCB
(SEE SHEET 2)**

**J88 2-PIN
CONNECTOR
MATES WITH
J88 ON
COMPRESSOR
HARNESS (SEE
SHEET 2)**

CLAMP

474 SHOWN 475/476 SIMILAR

**REFRIGERATED FOOD MODULE CABLE CONNECTIONS
(U.S. ONLY)**

FIGURE 4. SHEET 1 of 6

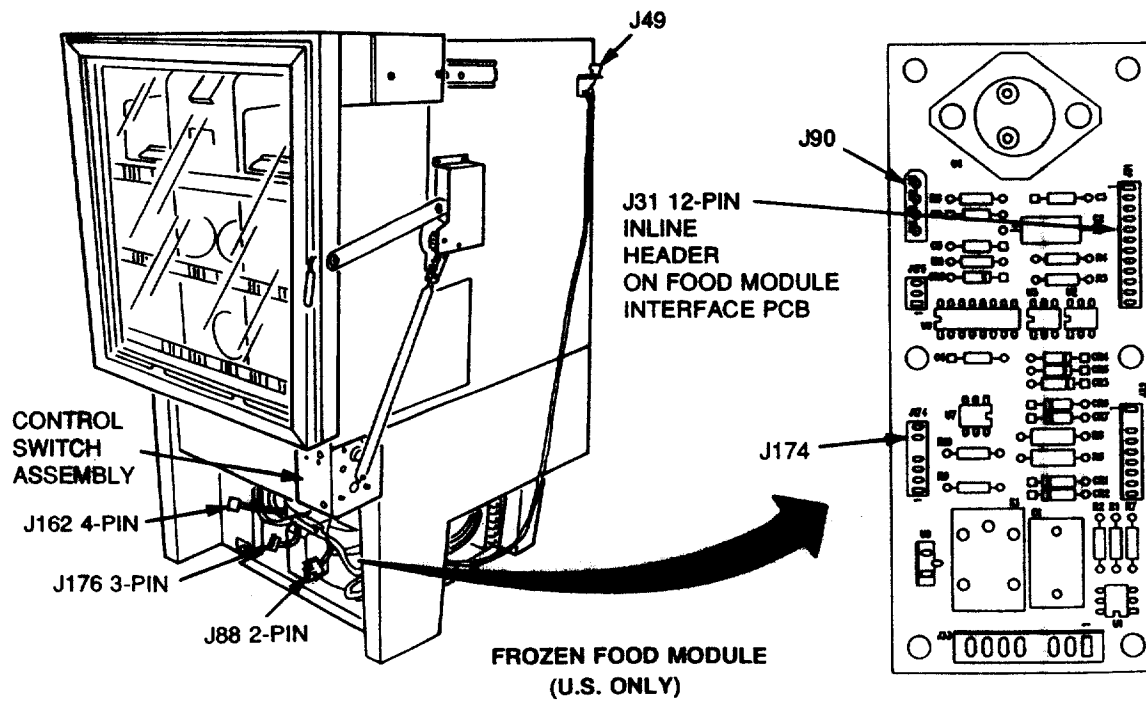
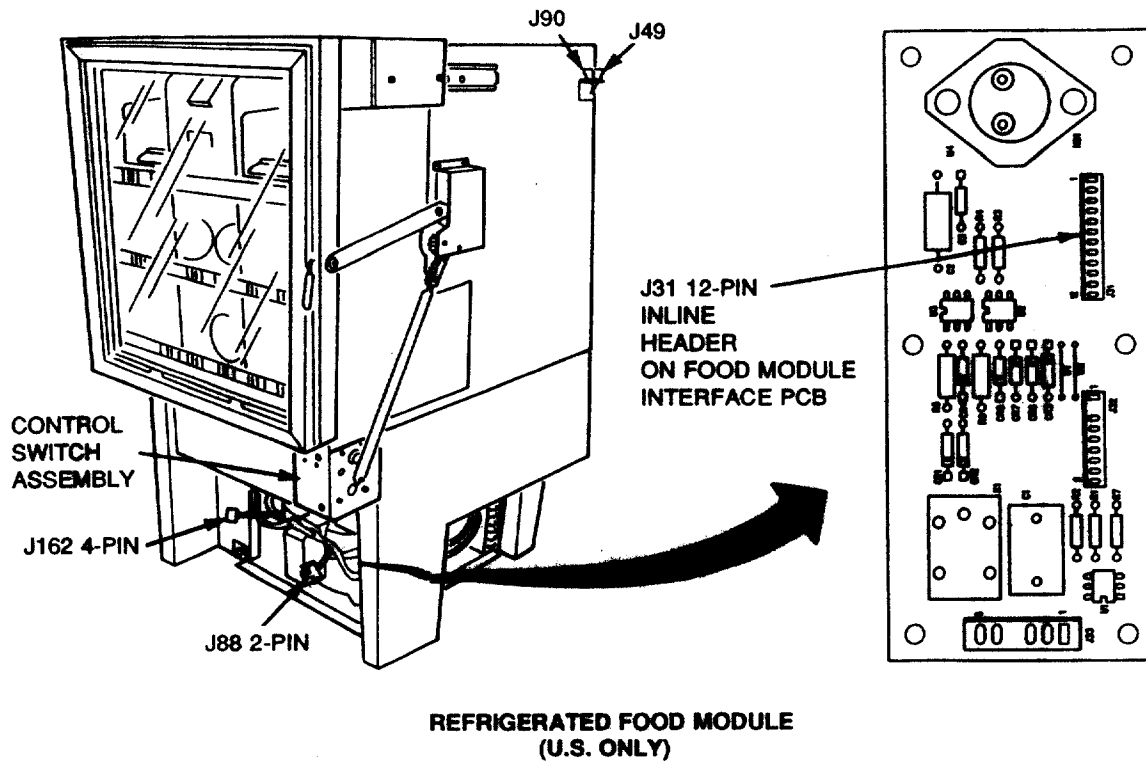

FIGURE 4. SHEET 2 of 6

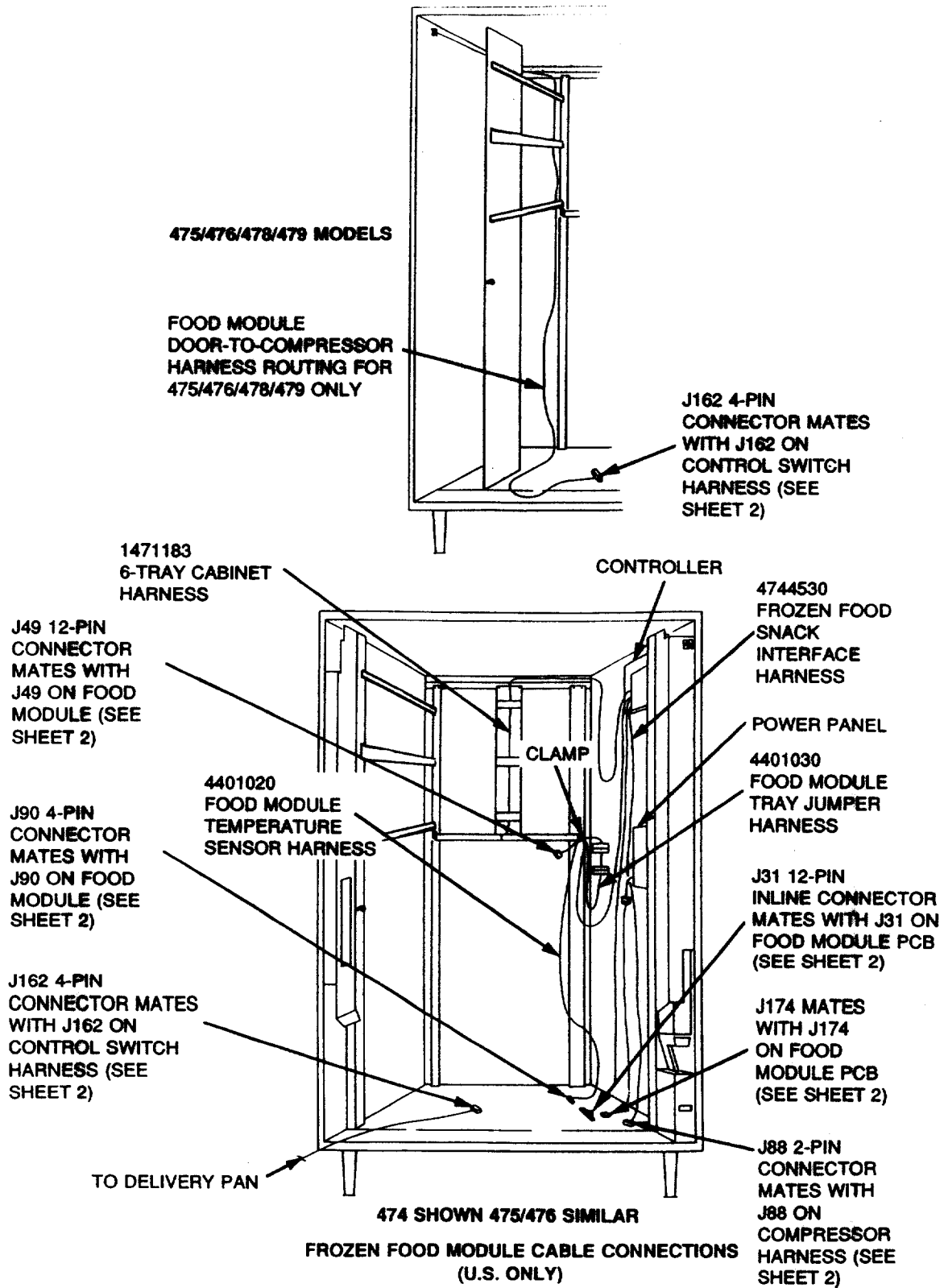

FIGURE 4. SHEET 3 of 6

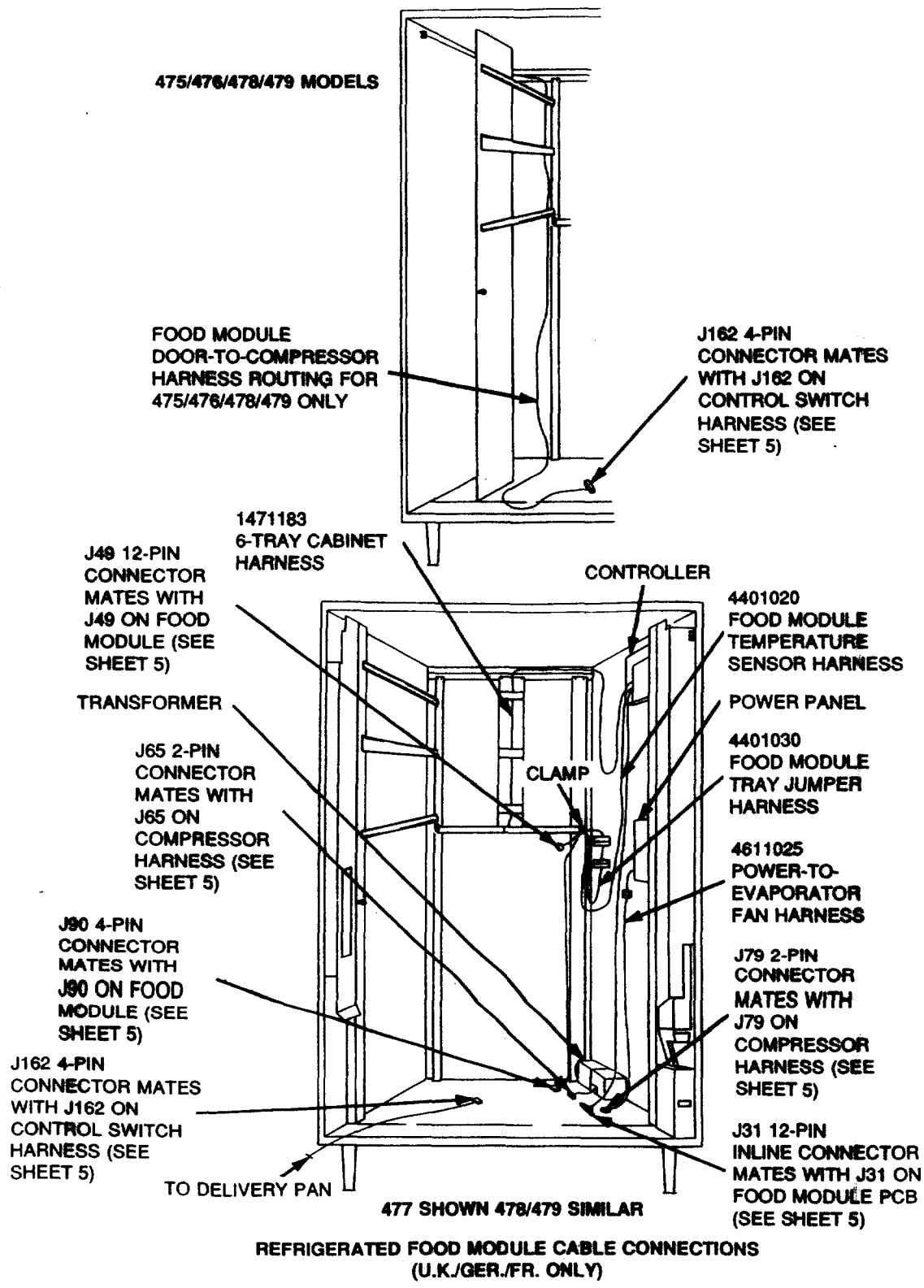

FIGURE 4. SHEET 4 of 6

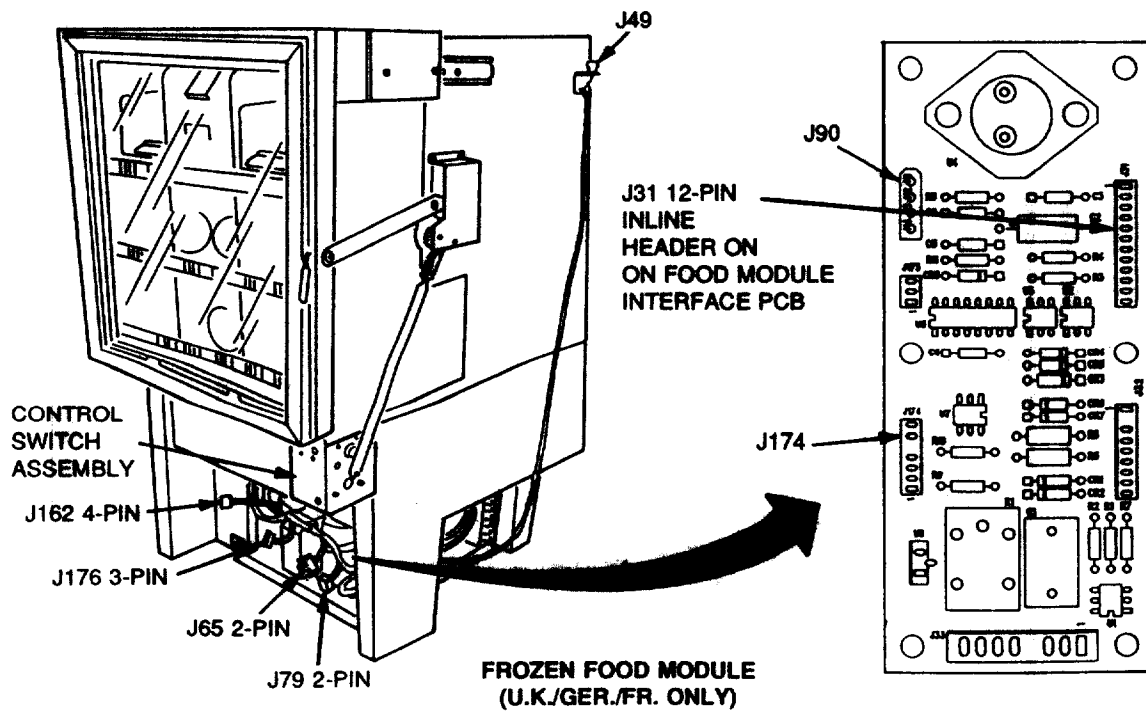
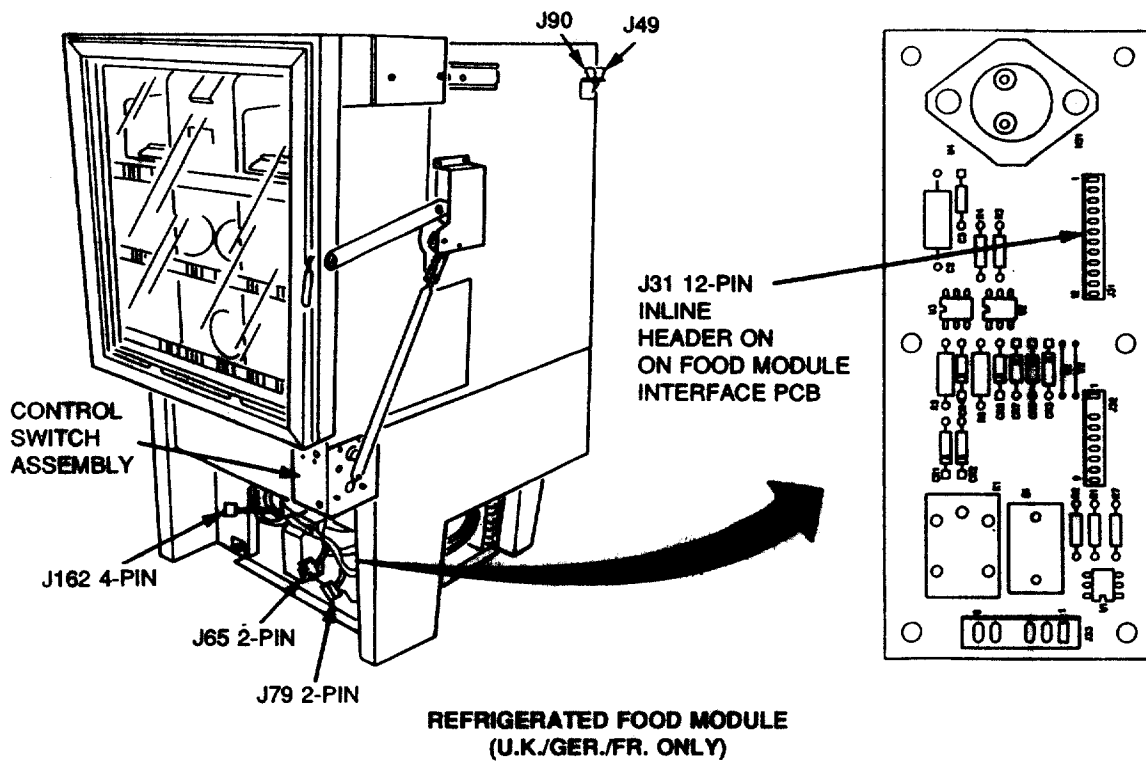

FIGURE 4. SHEET 5 of 6

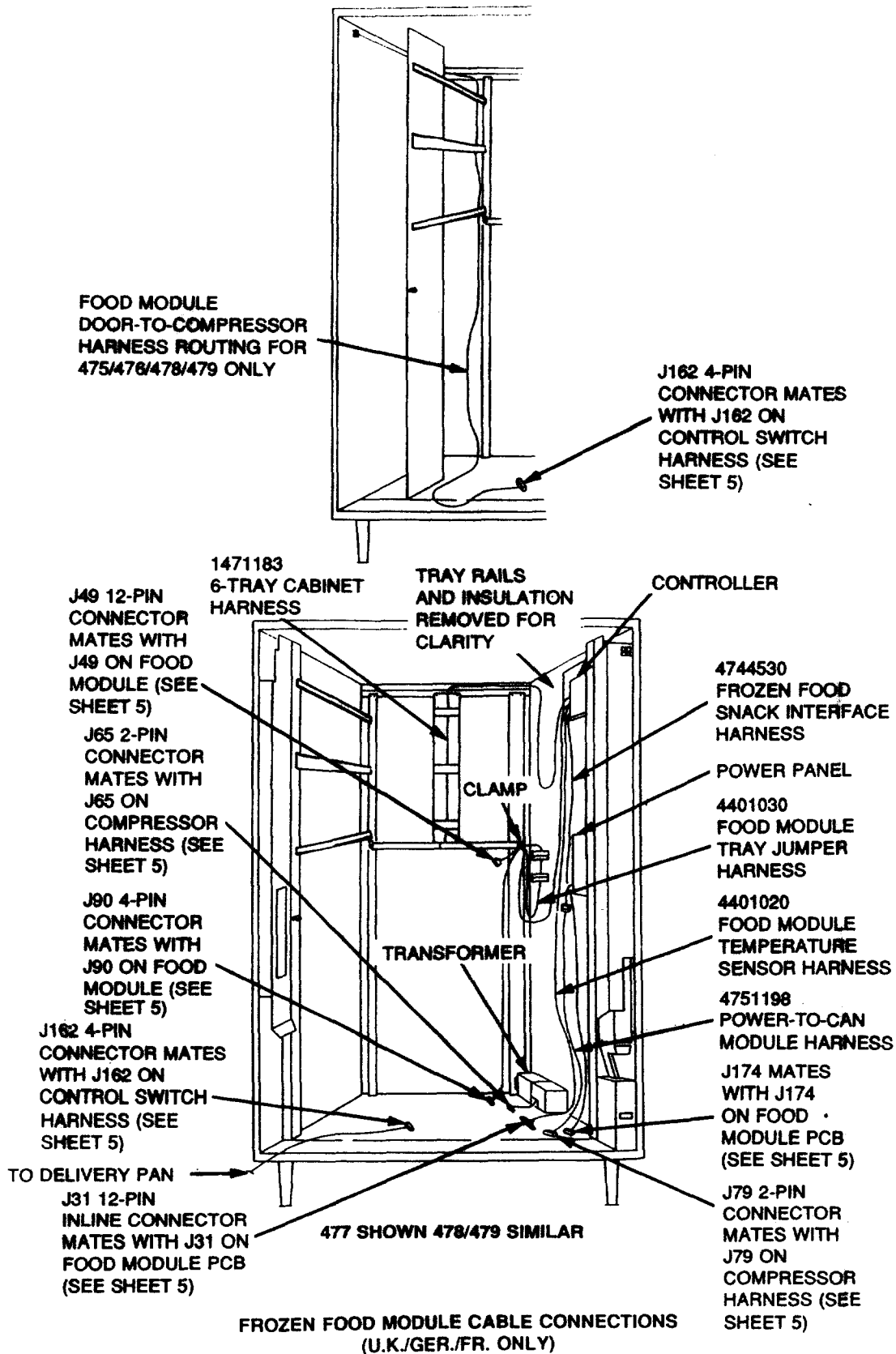

FIGURE 4. SHEET 6 of 6

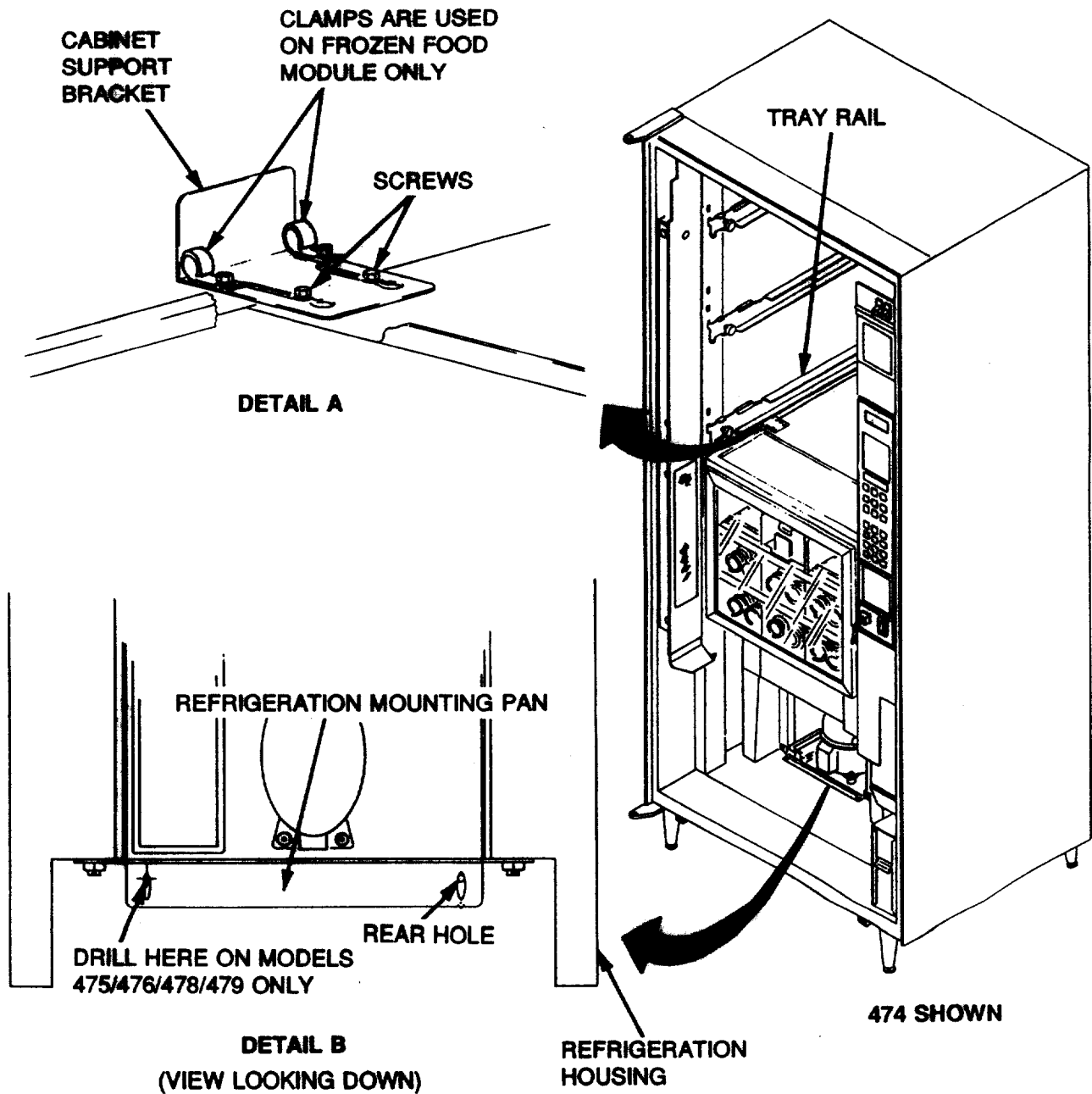

FIGURE 5.

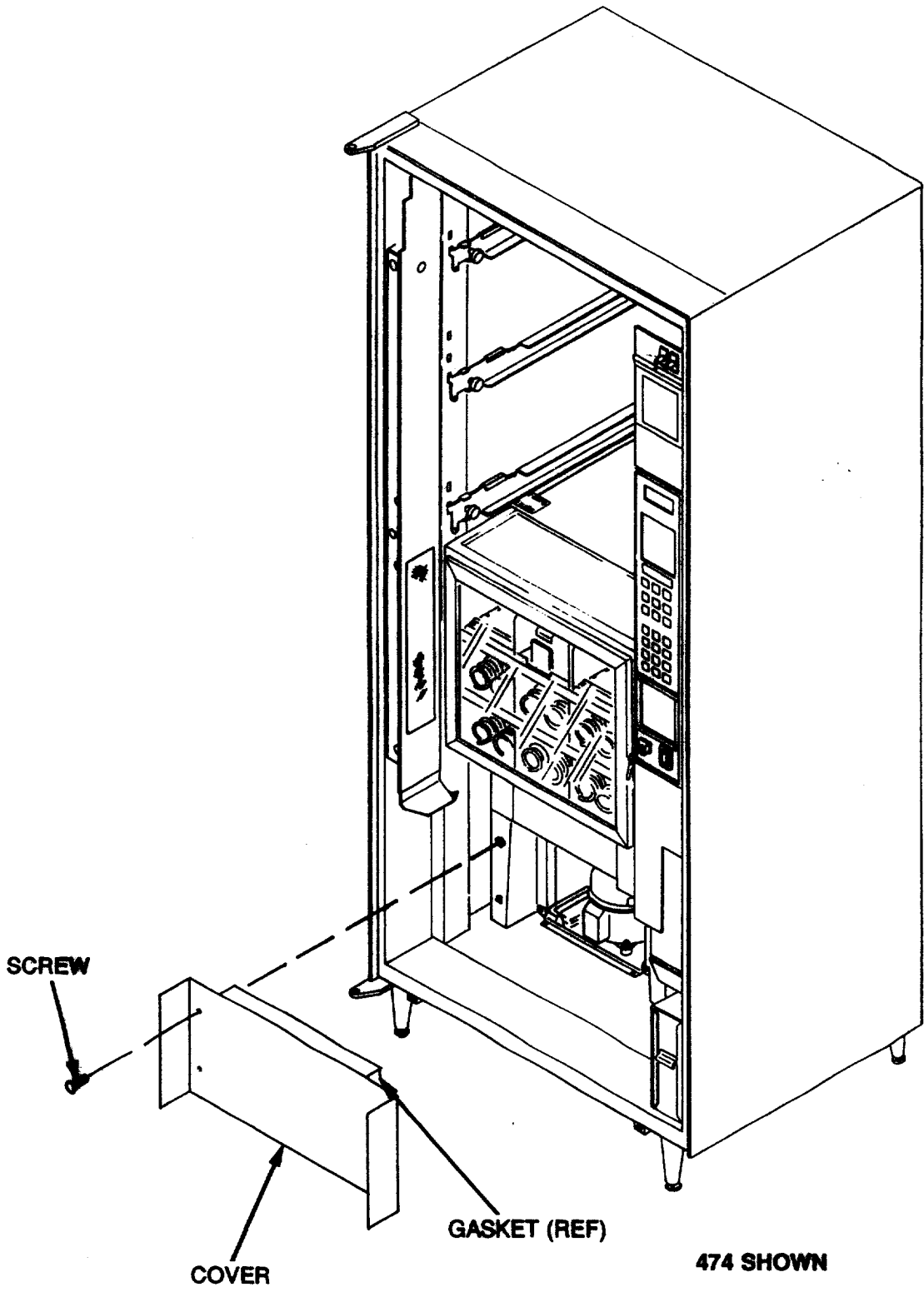

FIGURE 6.

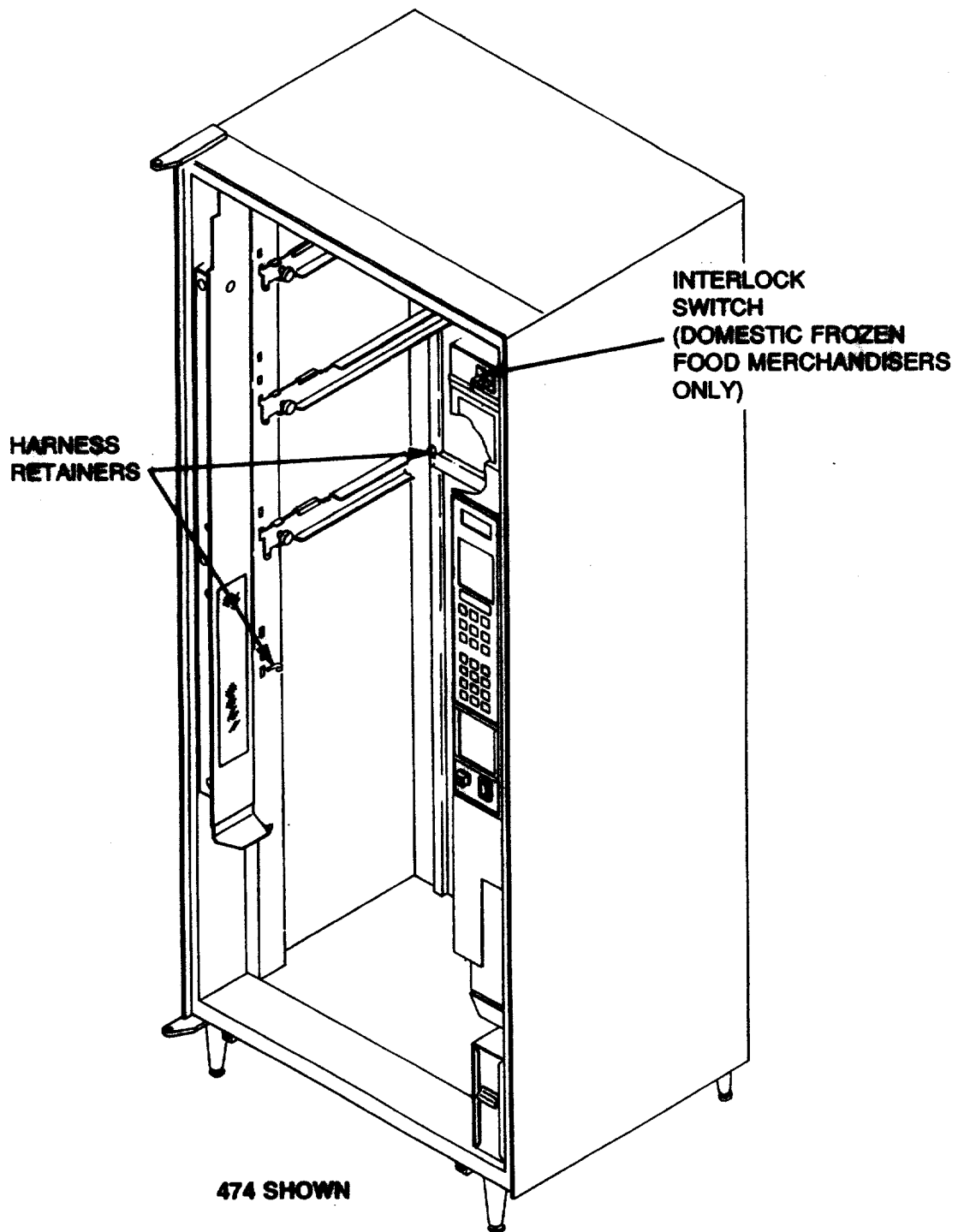

FIGURE 7.

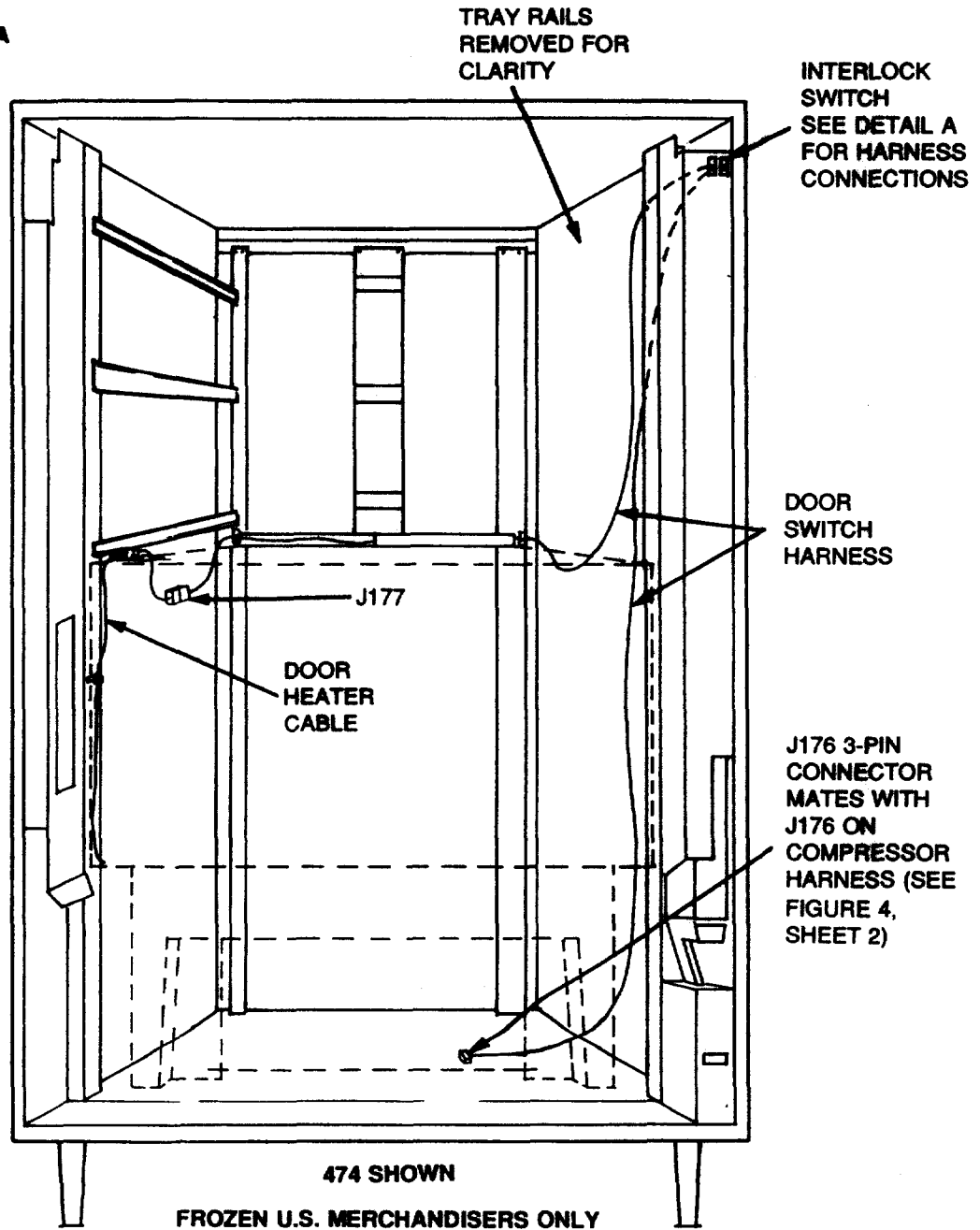
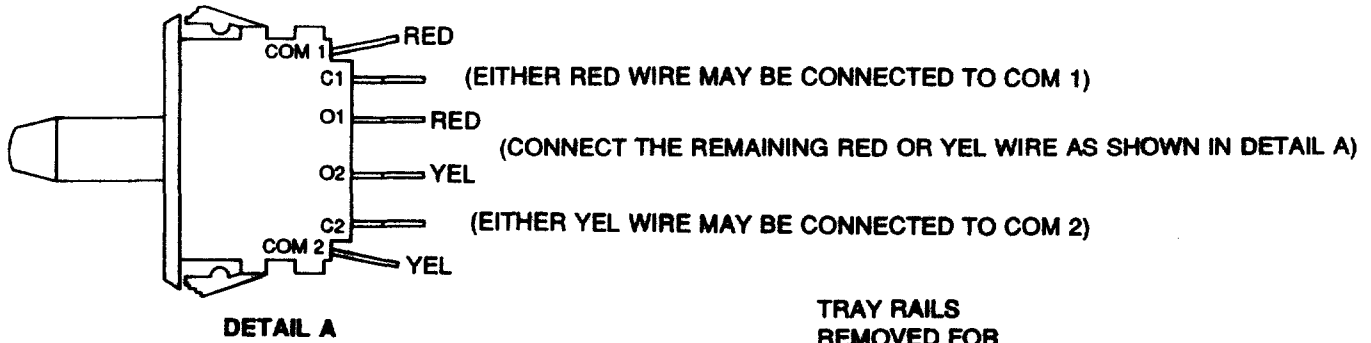
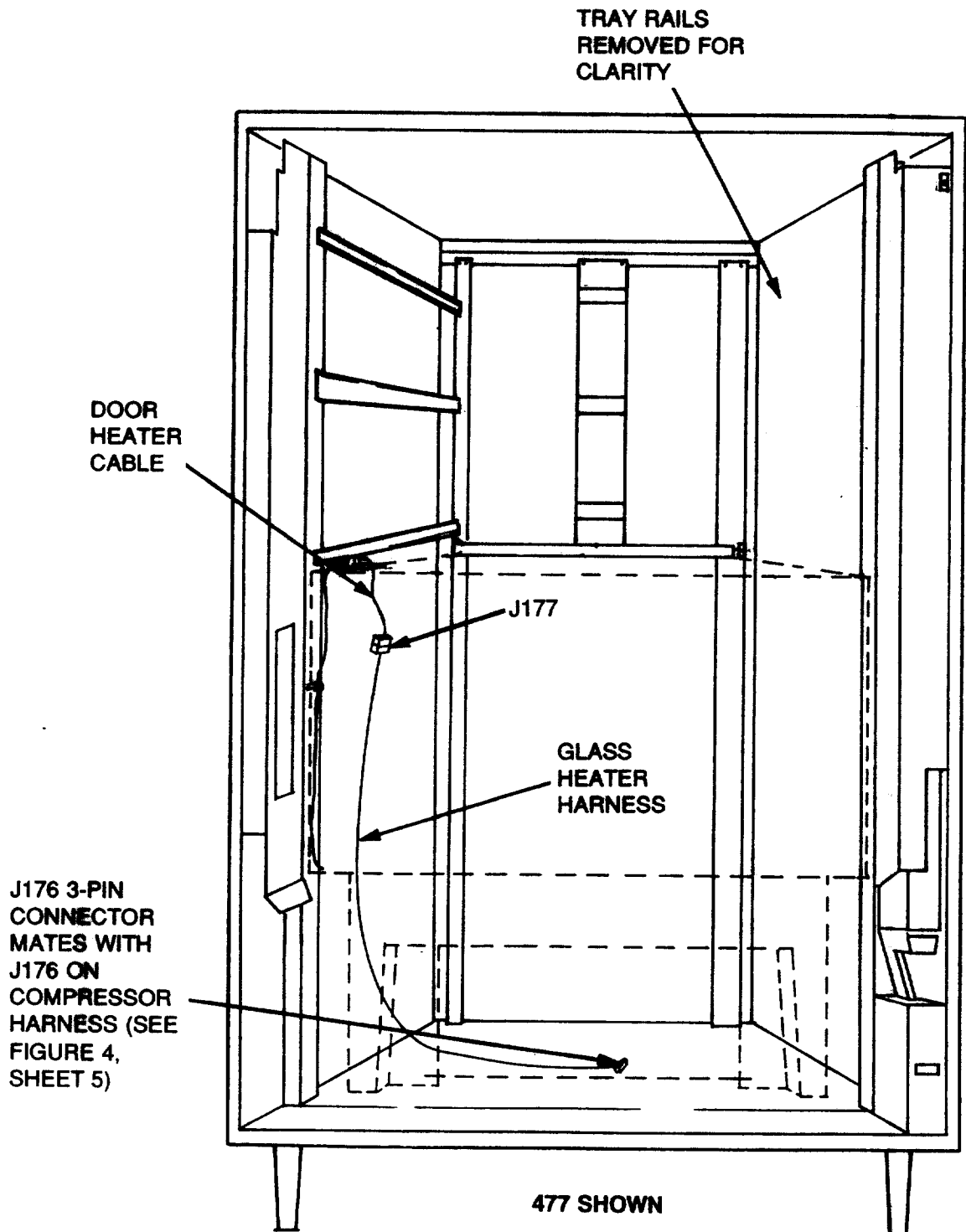

FIGURE 8. SHEET 1 of 2



FROZEN U.K./GER./FR. MERCHANDISERS ONLY

FIGURE 8. SHEET 2 of 2

**KIT PART NUMBER 4747810 (U.S.) and 4747813 (U.S.)
 KIT PART NUMBER 4777816 (U.K.) and 4777821 (U.K.)
 KIT PART NUMBER 4777817 (GER./FR.) and 4777822 (GER./FR.)**

**INSTRUCTIONS FOR INSTALLING A REFRIGERATED OR FROZEN FOOD MODULE
 IN A 474, 475, 476, 477, 478, OR 479 MERCHANDISER WITH AN 8 SELECTION CAN UNIT**

**CHECK THE PARTS RECEIVED IN THE KIT WITH THE PARTS LIST
 IN THESE INSTRUCTIONS. IF ANY PARTS ARE MISSING,
 CONTACT NATIONAL VENDORS' PARTS DEPARTMENT IMMEDIATELY.**

Read these instructions carefully before installing the kit.
 Retain these instructions for part numbers and for future reference.

Tables 1 thru 4 list parts for the kit you purchased. Determine if you have a refrigerated or frozen food kit and domestic (U.S.) or foreign application, then locate the table which lists the parts for your kit.

Table 1. Refrigerated Food Kit 4747810 (Domestic - U.S.)

PART NUMBER	DESCRIPTION	QTY
4747800	Refrigerated Food Module and Refrigeration Module Assembly - Domestic	1
4741213	Cover and Seal Assembly - Compressor	1
4740021	Plastic Bag Assembly - Refrig/Frz Food - Domestic	1
4747715	Bracket - Cabinet Support	2
4727144	Screw - #8-18 x .62, Hex Hd	8
1141046	Screw - #10-32 x 3/8, Acorn Hex Washer Head	2
4740016	Divider and Spiral Package	1
4407807	Divider and Spring Assembly	2
4407820	Spiral and Retainer - 6 Count/LH, Grn	1
4407823	Spiral and Retainer - 6 Count/RH, Grn	1
1170206	Screw - #8-32 x 3/8, THS, BLK	7
1451097	Screw - #8-32 x .31, Hex Hd, T/F, BLK	13
1452139	Retainer - Harness	1
4401008	Deflector - Product	1
4401014	Light - Fluorescent	1
4401026	Angle - Receptacle Mounting	1
4402021	Latch - Mounting Plate Assembly	1
4402026	Harness - Delivery Pan - Ref 2 - Food Module	1
4402027	Cover - Latch Mechanism	1
4402028	Deflector - LH	1
4402032	Plate and Filler Assembly (Filler Panel)	1
4422002	Harness - Delivery Pan	1
4422005	Brace - End Plate - Left	1
4422006	End Plate - Display - Left	1

Table 2. Frozen Food Kit 4747813 (Domestic - U.S.)

PART NUMBER	DESCRIPTION	QTY
4747700	Frozen Food Module and Refrigeration Module Assembly - Domestic	1
4741213	Cover and Seal Assembly - Compressor	1
4740021	Plastic Bag Assembly - Refrig/Frz Food - Domestic	1
4747715	Bracket - Cabinet Support	1
4727144	Screw - #8-18 x .62, Hex Hd	8
1141046	Screw - #10-32 x 3/8, Acorn Hex Washer Head	2
4740016	Divider and Spiral Package	1
4407807	Divider and Spring Assembly	2
4407820	Spiral and Retainer - 6 Count/LH, Gm	1
4407823	Spiral and Retainer - 6 Count/RH, Gm	1
4747714	Bracket and Clamp Assembly - Cabinet Support	1
1211141	Switch - 2DM4	1
1451097	Screw - #8-32 x .31, Hex Hd, T/F	2
2342315	Retainer - Harness	2
4042121	Wire Tie - Self-Clinching	2
4741212	Harness - Glass Heater - Domestic	1
1170206	Screw - #8-32 x 3/8, THS, BLK	7
1451097	Screw - #8-32 x .31, Hex Hd, T/F, BLK	13
1452139	Retainer - Harness	1
4401008	Deflector - Product	1
4401014	Light - Fluorescent	1
4401026	Angle - Receptacle Mounting	1
4402021	Latch - Mounting Plate Assembly	1
4402026	Harness - Delivery Pan - Ref 2 - Food Module	1
4402027	Cover - Latch Mechanism	1
4402028	Deflector - LH	1
4402032	Plate and Filler Assembly (Filler Panel)	1
4422002	Harness - Delivery Pan	1
4422005	Brace - End Plate - Left	1
4422006	End Plate - Display - Left	1

Table 3. Refrigerated Food Kit 4777816/4777817 (Foreign - U.K./GER./FR.)

PART NUMBER	DESCRIPTION	QTY
4777808	Refrigerated Food Module and Refrigeration Module Assembly - Foreign	1
4741213	Cover and Seal Assembly - Compressor	1
4770025	Plastic Bag Assembly - Refrig/Frz Food - UK	1
4770027	Plastic Bag Assembly - Refrig/Frz Food - GER/FR	1
4407001	Bracket - Cabinet Support	2
4727144	Screw - #8-18 x .62, Hex Hd	8
1141046	Screw - #10-32 x 3/8, Acorn Hex Washer Head	2
4740016	Divider and Spiral Package	1
4407807	Divider and Spring Assembly	2
4407820	Spiral and Retainer - 6 Count/LH, Gm	1
4407823	Spiral and Retainer - 6 Count/RH, Gm	1
1170206	Screw - #8-32 x 3/8, THS, BLK	7

PART NUMBER	DESCRIPTION	QTY
4777806	Refrigerated Food Module and Refrigeration Module Assembly - Foreign	1
1451097	Screw - #8-32 x .31, Hex Hd, T/F, BLK	13
1452139	Retainer - Harness	1
4401008	Deflector - Product	1
4401014	Light - Fluorescent	1
4401026	Angle - Receptacle Mounting	1
4402021	Latch - Mounting Plate Assembly	1
4402026	Harness - Delivery Pan - Ref 2 - Food Module	1
4402027	Cover - Latch Mechanism	1
4402028	Deflector - LH	1
4402032	Plate and Filler Assembly (Filler Panel)	1
4422002	Harness - Delivery Pan	1
4422005	Brace - End Plate - Left	1
4422006	End Plate - Display - Left	1

Table 4. Frozen Food Kit 4777821/4777822 (Foreign - U.K./GER./FR.)

PART NUMBER	DESCRIPTION	QTY
4777804	Frozen Food Module and Refrigeration Module Assembly - Foreign	1
4741213	Cover and Seal Assembly - Compressor	1
4770025	Plastic Bag Assembly - Refrig/Frz Food - UK	1
4770027	Plastic Bag Assembly - Refrig/Frz Food - GER/FR	1
4747715	Bracket - Cabinet Support	1
4727144	Screw - #8-18 x .62, Hex Hd	8
1141046	Screw - #10-32 x 3/8, Acorn Hex Washer Head	2
4740016	Divider and Spiral Package	1
4407807	Divider and Spring Assembly	2
4407820	Spiral and Retainer - 6 Count/LH, Grn	1
4407823	Spiral and Retainer - 6 Count/RH, Grn	1
4747714	Bracket and Clamp Assembly - Cabinet Support	1
2342315	Retainer - Harness	2
4042121	Wire Tie - Self-Clinching	2
4741225	Harness - Glass Heater - Foreign	1
1170206	Screw - #8-32 x 3/8, THS, BLK	7
1451097	Screw - #8-32 x .31, Hex Hd, T/F, BLK	13
1452139	Retainer - Harness	1
4401008	Deflector - Product	1
4401014	Light - Fluorescent	1
4401026	Angle - Receptacle Mounting	1
4402021	Latch - Mounting Plate Assembly	1
4402026	Harness - Delivery Pan - Ref 2 - Food Module	1
4402027	Cover - Latch Mechanism	1
4402028	Deflector - LH	1
4402032	Plate and Filler Assembly (Filler Panel)	1
4422002	Harness - Delivery Pan	1
4422005	Brace - End Plate - Left	1
4422006	End Plate - Display - Left	1

PERFORM THE FOLLOWING STEPS TO PREPARE THE MERCHANDISER FOR KIT INSTALLATION:

1. Remove all packaging materials from the kit.

WARNING

To prevent personnel injury or death, disconnect power from the merchandiser while performing these procedures.

2. Remove the bottom tray from the merchandiser. Refer to paragraph S-3 in the Mechanical Set-Up, Operation and Maintenance Manual.

NOTE

If you are converting from a 8 select can module to a refrigerated or frozen food module, refer to the Mechanical Set-Up, Operation and Maintenance Manual PN 1470058, paragraph M-16, for can module removal.

In the merchandiser cabinet: Refer to Figure 1 during the following procedures.

3. At the back of the cabinet, remove the cable shield from the receptacle mounting angle.
4. Remove the receptacle mounting angle.
5. Place the receptacle mounting angle (4401026) from the kit, in position and secure with four screws (1451097).
6. Attach the cable shield (4401024) to the receptacle mounting angle using the screws removed previously.
7. In order to install the fluorescent light assembly (4401014) to the LH display end plate, the LH end plate filler panel must first be removed. (Model 474/477 merchandisers only).
8. Separate the merchandiser fluorescent light jumpers located behind the LH end plate. See Figure 10, sheet 3. Do not confuse these harnesses with the gum & mint harness.
9. Insert the fluorescent light, with the harness on the righthand side, in the bottom of the LH end plate. Through the filler panel opening, connect the lower fluorescent light jumper to the bottom connector, J17A, on the fluorescent light.
10. Connect the upper fluorescent light jumper to the top connector, J18A, on the fluorescent light.
11. Use the black screws from the filler panel to attach the fluorescent light assembly (4401014) to the LH display end plate.
12. The product deflector attached to the bottom of the left hand display end plate must be removed. Models 474/477 only.

On the merchandiser door: Refer to Figure 2 while performing step 1:

Remove the gum and mint unit as follows:

1. Disconnect the gum & mint harness from the angle and motor assembly PCB. On model 474/477 merchandisers, coil the free end of the harness and secure with a cable tie behind the LH display end plate in the cabinet. On 475/6/8/9 merchandisers, leave the harness in the clamps on the door, fold the harness back on itself and secure the loose end to the harness with a cable tie. See Detail A, Figure 2.

Refer to Figure 3 during the following step:

2. Loosen the four screws mounting the angle and motor assembly to the delivery pan and remove the angle and motor assembly.

Refer to Figure 4 while performing steps 3 and 4:

3. Remove the gum & mint magazine by loosening the four pivot studs and nuts securing the magazine to the delivery pan.

4. Install the delivery pan filler panel (4402032) from the kit, to the delivery pan where the magazine was removed. Use four screws (1170206) to attach the filler panel.

Refer to Figure 5 while performing steps 5 and 6:

5. On merchandiser models 475/476/478/479, the LH display end plate should be removed next.

6. On merchandiser models 474/477, remove the gum & mint support rod bracket and support rod.

Refer to Figure 6, while performing steps 7 and 8.

7. To mount the latch mounting plate assembly to the delivery pan, raise the rear delivery door assembly with one hand until the left hand actuator is clear of the stud and nut behind it. Remove the nut.

8. Remove the remaining required nuts and screws per Figure 6.

9. Install the latch mounting plate assembly as shown in Figure 7. Position the LH actuator as described in step 7 to enable installation of the nut behind the actuator.

10. Install the remaining fasteners as shown in Figure 7.

11. Without power applied to the merchandiser, ensure that both switches on the latch mounting assembly are in the closed position as shown in Figure 7. An audible "click" can be heard when the switch closes. If switch J169 does not close when the solenoid plunger is fully extended or J161 does not close when the LH actuator assembly is fully forward, adjust the switch position. Do this by loosening the switch mounting fasteners and moving the switch toward the actuator.

12. Mount the left hand product deflector (4401008) to the delivery pan. See Figure 6.

Refer to Figure 8 while performing steps 13 and 14.

13. On model 475/6/8/9 merchandisers, assemble the fluorescent light assembly (4401014) to the LH display end plate with four screws (1170206) and four nuts (9900081). Prepare the fluorescent light for installation as shown in Detail A, Figure 8.

14. Mount the left hand display end plate (4401027) to the door with seven screws (1170206).

CAUTION

At least two people are required to move the food module because of its weight. Exercise caution to prevent personnel injury.

Refer to Figure 9 while performing step 15:

15. Two people will be required to lift and slide the food module partially into the merchandiser cabinet.
16. Connect the harnesses as shown in Figure 10. Sheets 1 through 5 cover delivery pan switches and fluorescent light connections. Sheets 6 through 11 show how to make harness connections for refrigerated or frozen food modules.
17. Install the latch mounting assembly cover. See Figure 8.

Refer to Figure 11 during the following procedure:

18. Slide the food module fully into the merchandiser cabinet. Secure the refrigeration module to the merchandiser floor using two screws (1141046). Install these screws in the same holes as the can module.

Refer to Figure 11, Detail A during the following procedure:

19. Mount the cabinet support brackets on the top of the food module housing on the right and left sides using two screws (4727144) per bracket. Make sure the brackets are outside the tray rails.

Refer to Figure 12 during the following procedure:

20. Install the refrigeration assembly cover and secure in place using four screws (4727144).
21. Install the tray removed in step 2 and restore power to the merchandiser.
22. See the Food Module Supplement P/N 1470052, in the Mechanical Set-Up, Operation and Maintenance Manual P/N 1470058, for food module set-up procedures.
23. See the Food Module Programming Supplement P/N 1470053, in the Programming Guide P/N 1470059, for programming procedures for the food module.

PERFORM THE FOLLOWING STEPS TO INSTALL A FROZEN FOOD MODULE IN THE MERCHANDISER:

WARNING

To prevent personnel injury or death, disconnect power from the merchandiser while performing these procedures.

Refer to Figure 13 while performing the following procedure:

1. Install one harness retainer on the left side of the cabinet below the bottom tray rail and secure with one screw (1451097).

2. Install one harness retainer on the left rear channel of the merchandiser cabinet and secure with one screw (1451097). (U.S. merchandisers only)

Refer to Figure 14, Sheet 1 while performing the following step.

3. Install the door heater harness and interlock switch.

4. Repeat steps 15 thru 19 of the refrigerated food installation procedures.

Refer to Figure 14, Sheet 1 while performing steps 5 and 6.

5. Route the door heater cable through the harness retainer you installed on the left side of the merchandiser cabinet and through the harness retainers on the left cabinet support bracket assembly.

6. Connect the door heater cable (J177) to the merchandiser door switch cable (J177).

Refer to Figure 14, Sheet 2 while performing the following step.

7. On merchandisers located outside the U.S. (U.K./GER./FR.), route the door heater cable through the harness retainer you installed on the left side of the merchandiser cabinet, through the harness retainers on the left cabinet support bracket assembly, then down to the refrigeration assembly connector (J176).

8. Repeat Steps 20 thru 23 of the refrigerated food installation procedures.

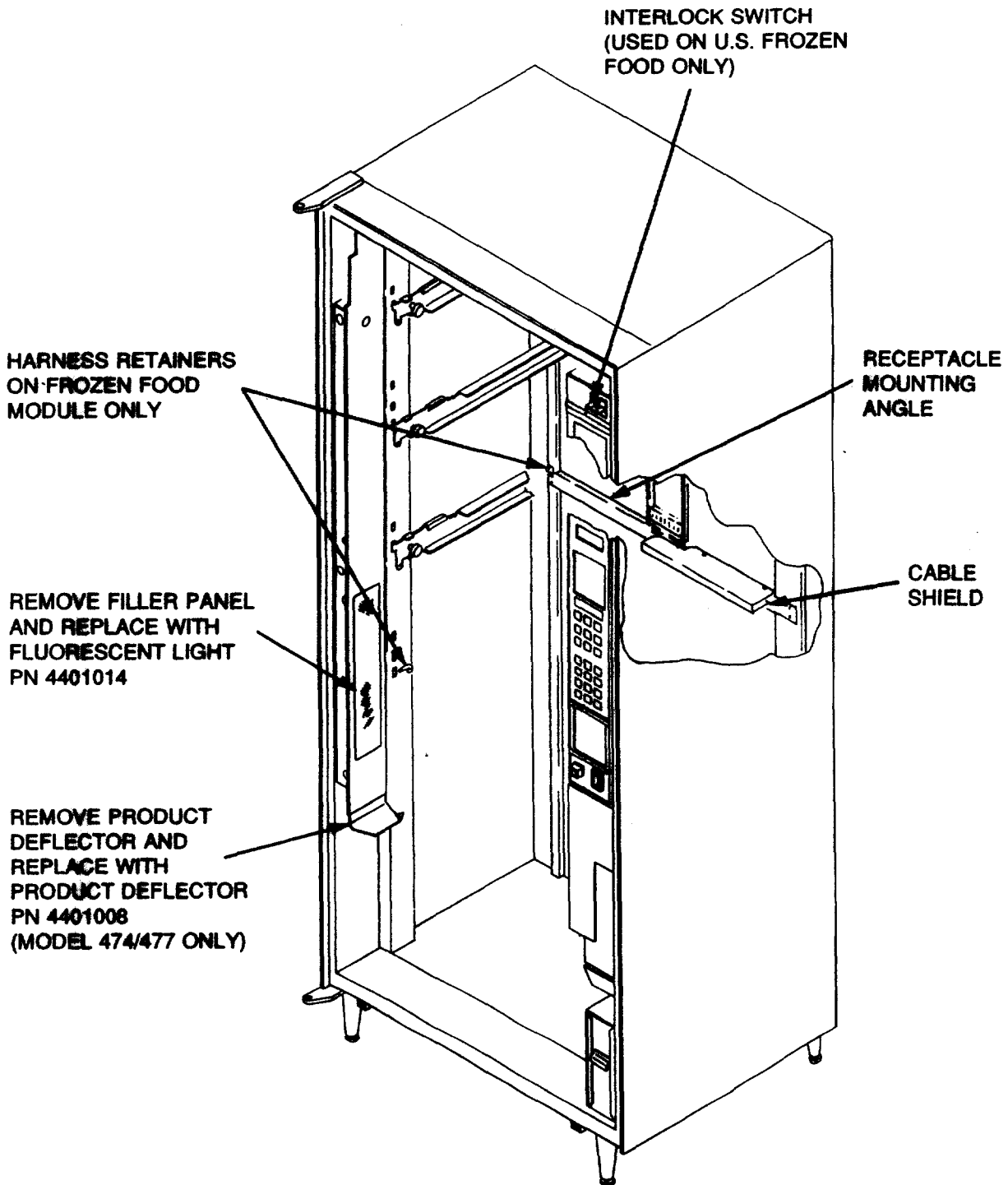

474/477 SHOWN

FIGURE 1.

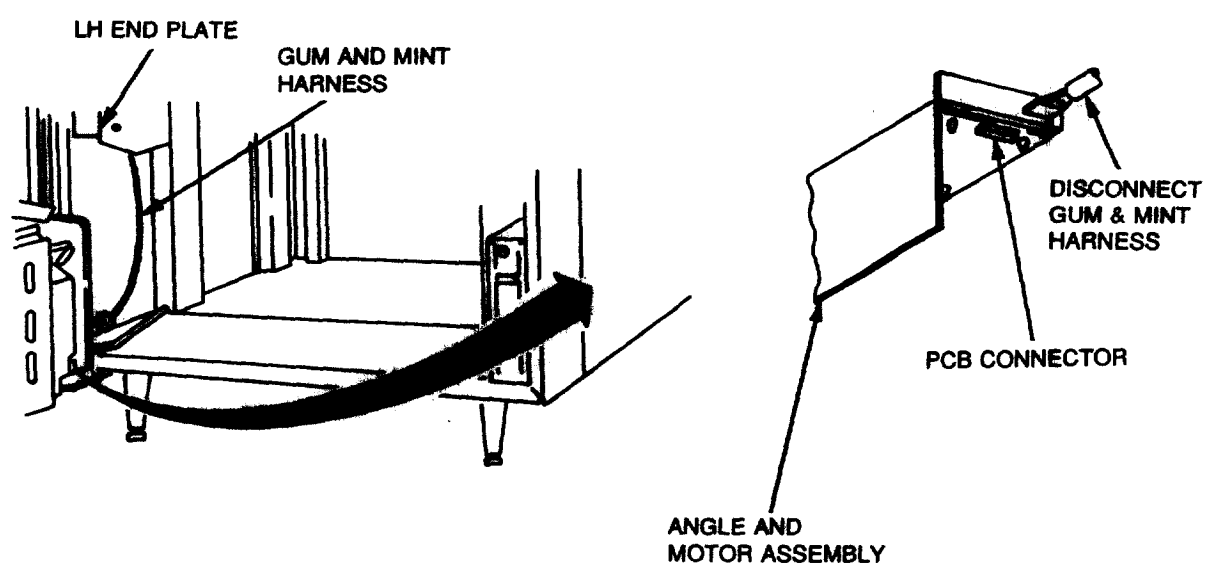
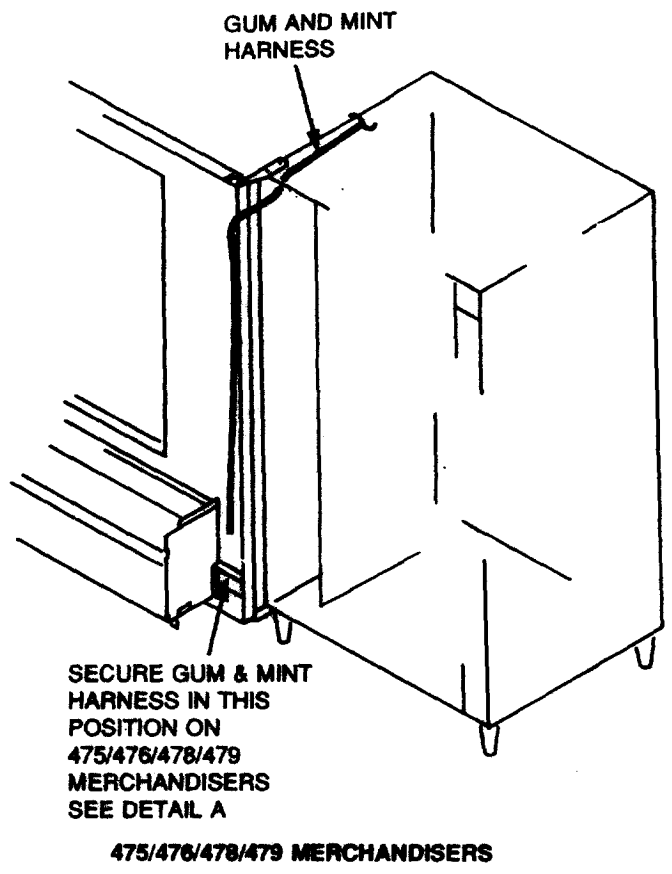
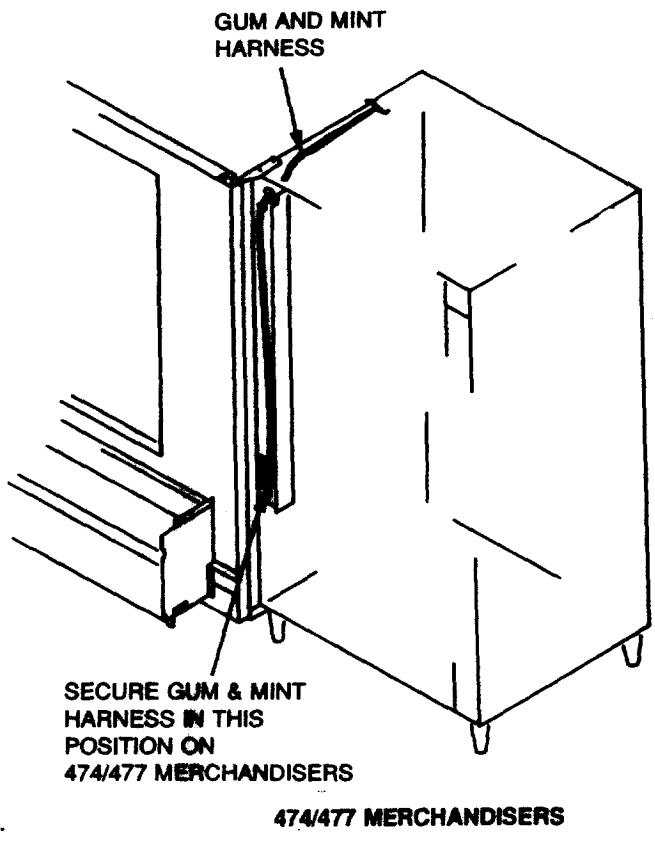
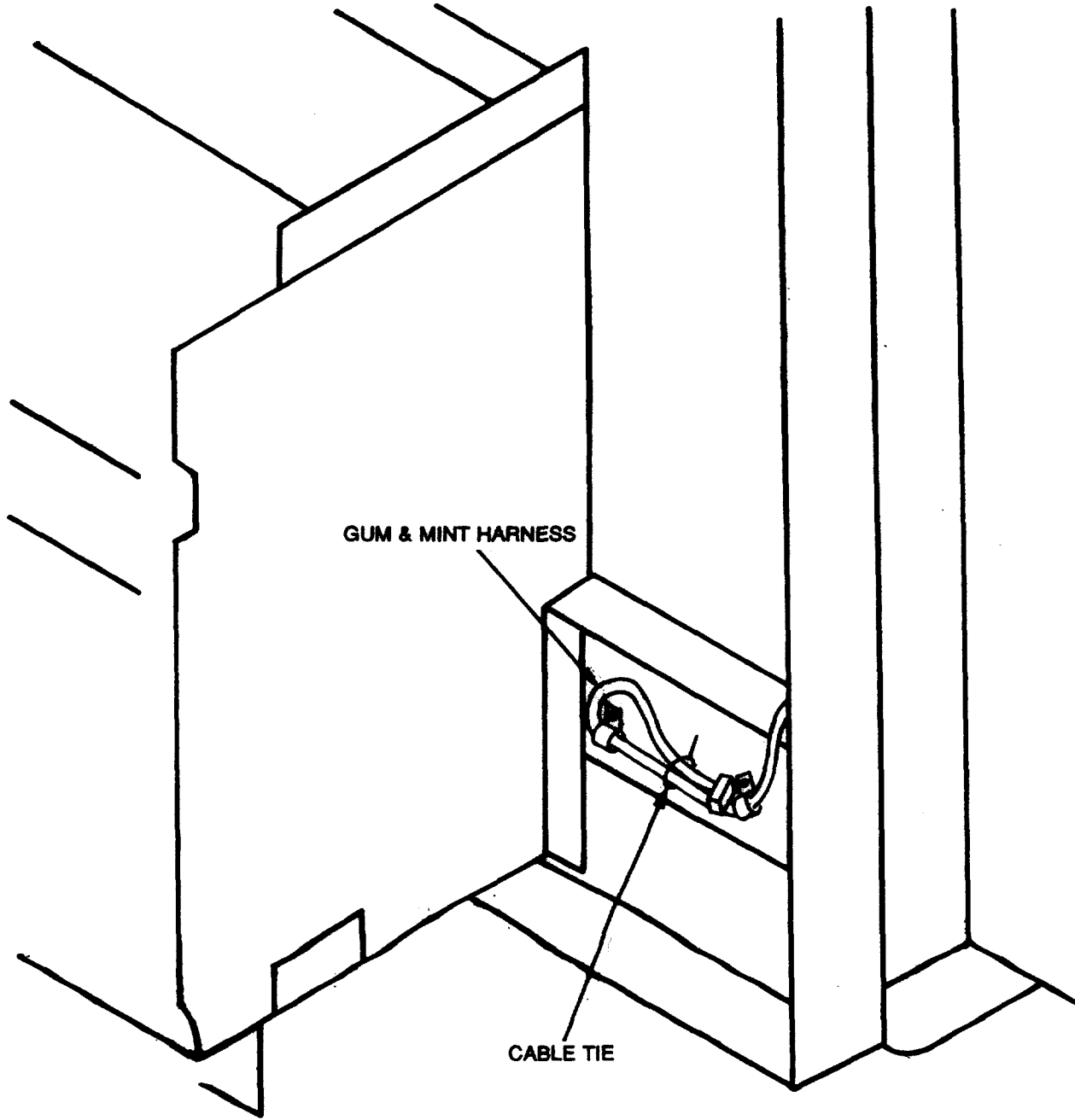

FIGURE 2. SHEET 1 of 2



GUM & MINT HARNESS

CABLE TIE

DETAIL A

FIGURE 2. SHEET 2 of 2

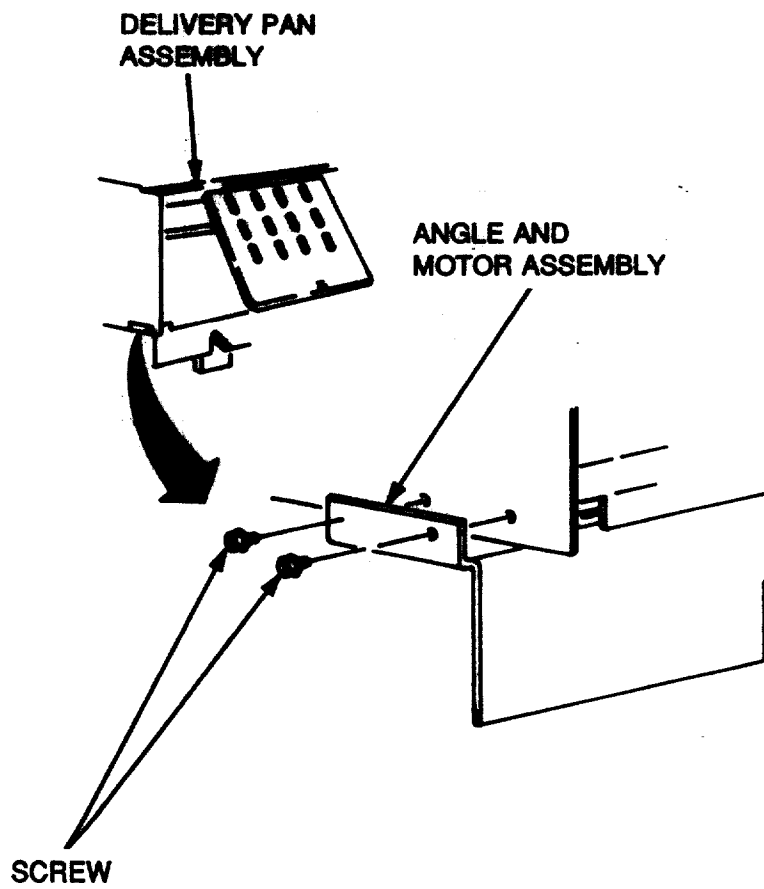
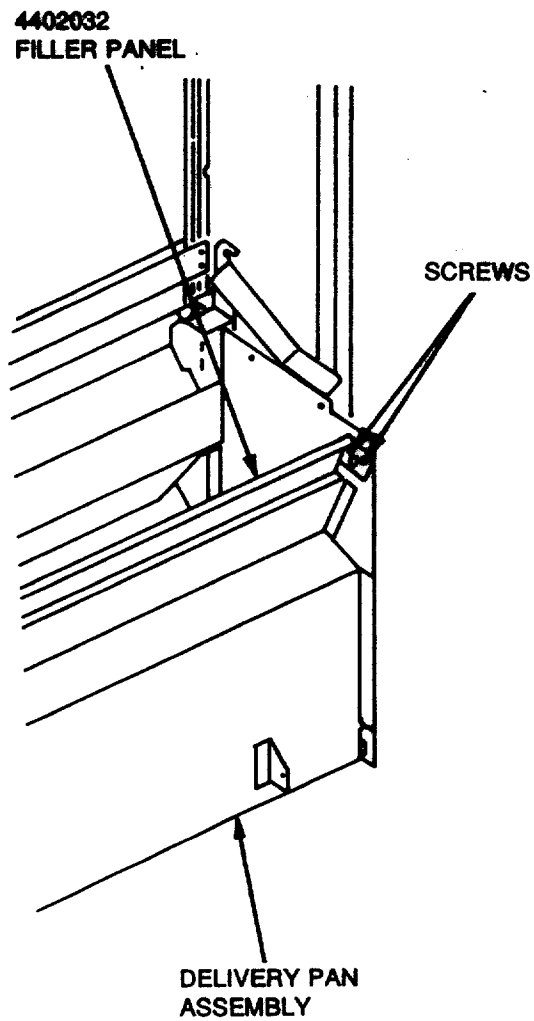
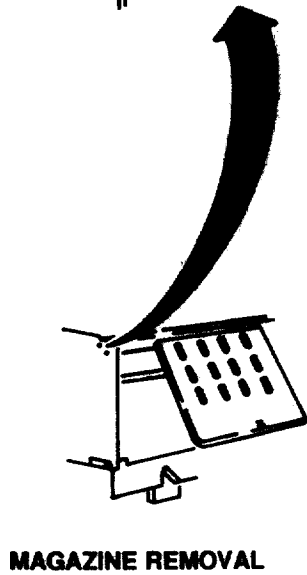
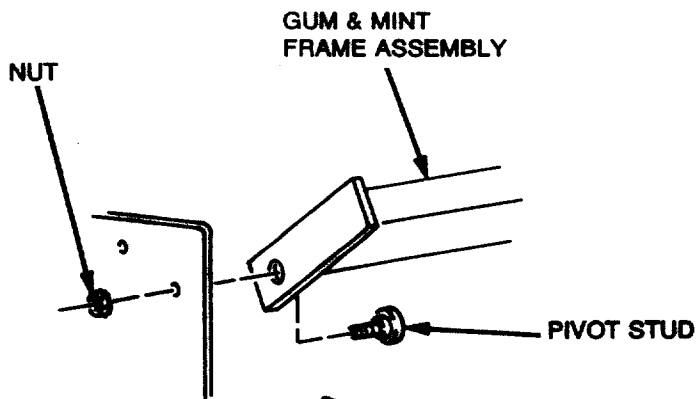

FIGURE 3.



FILLER PANEL INSTALLATION

FIGURE 4.

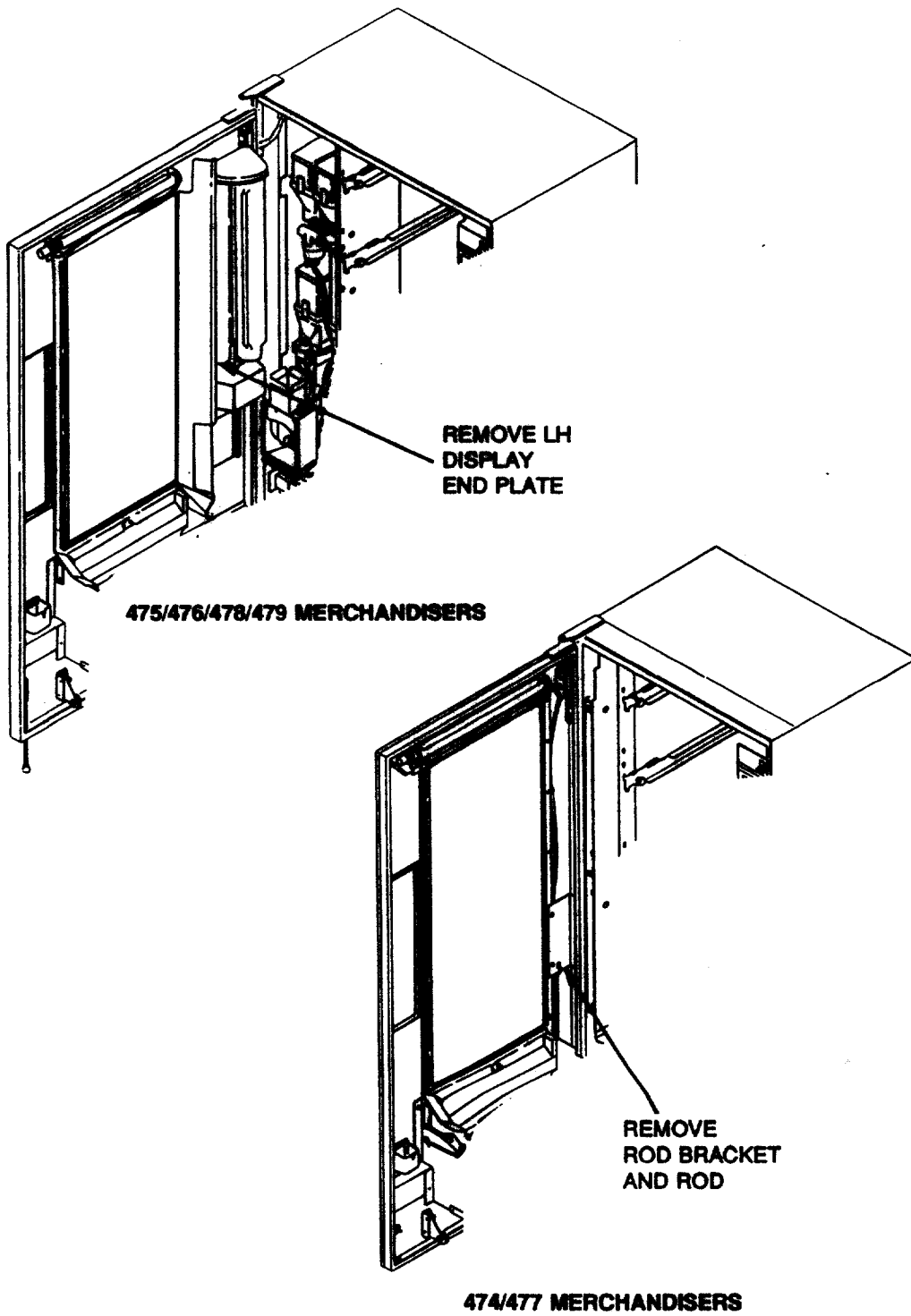

FIGURE 5.

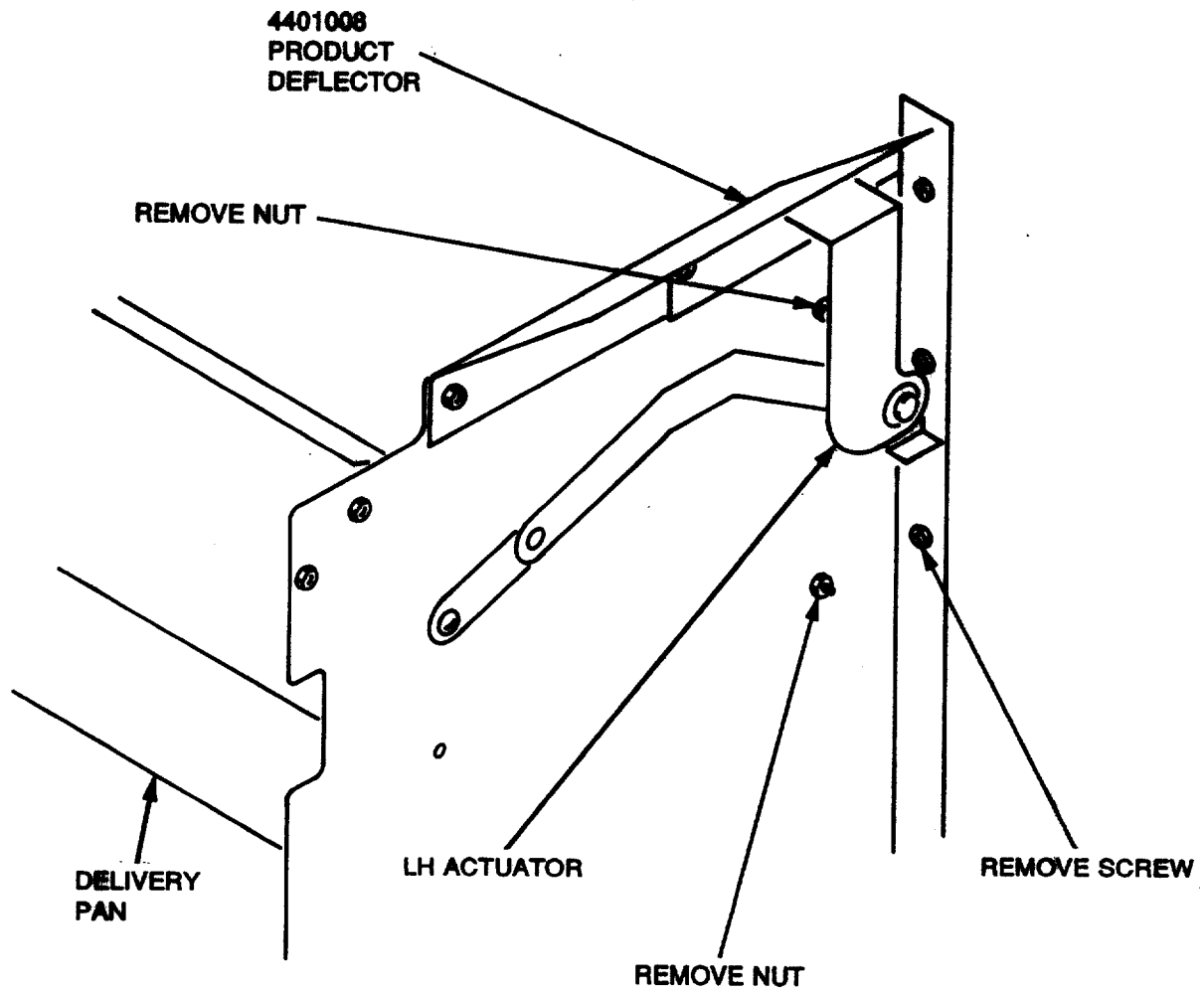

FIGURE 6.

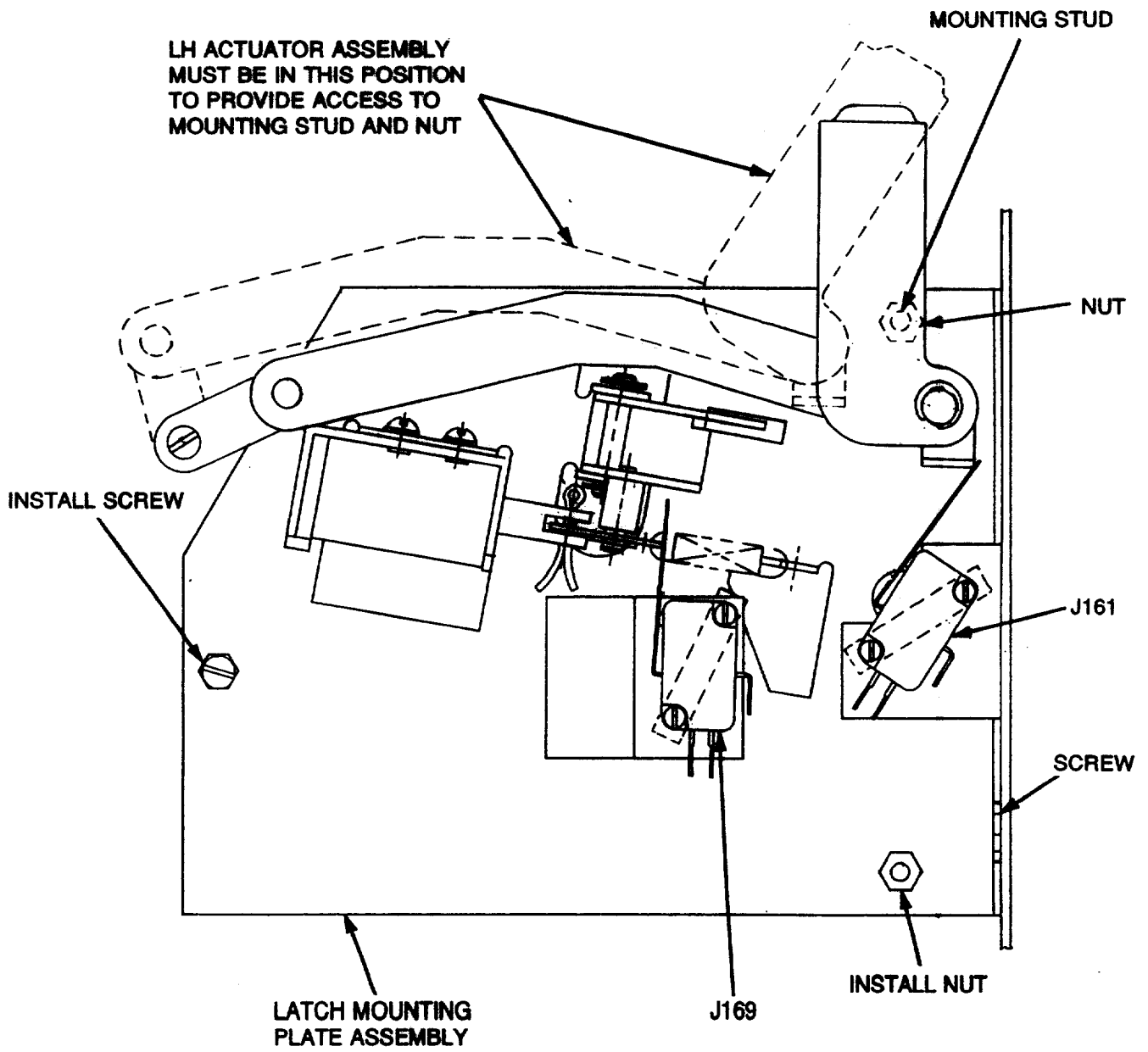
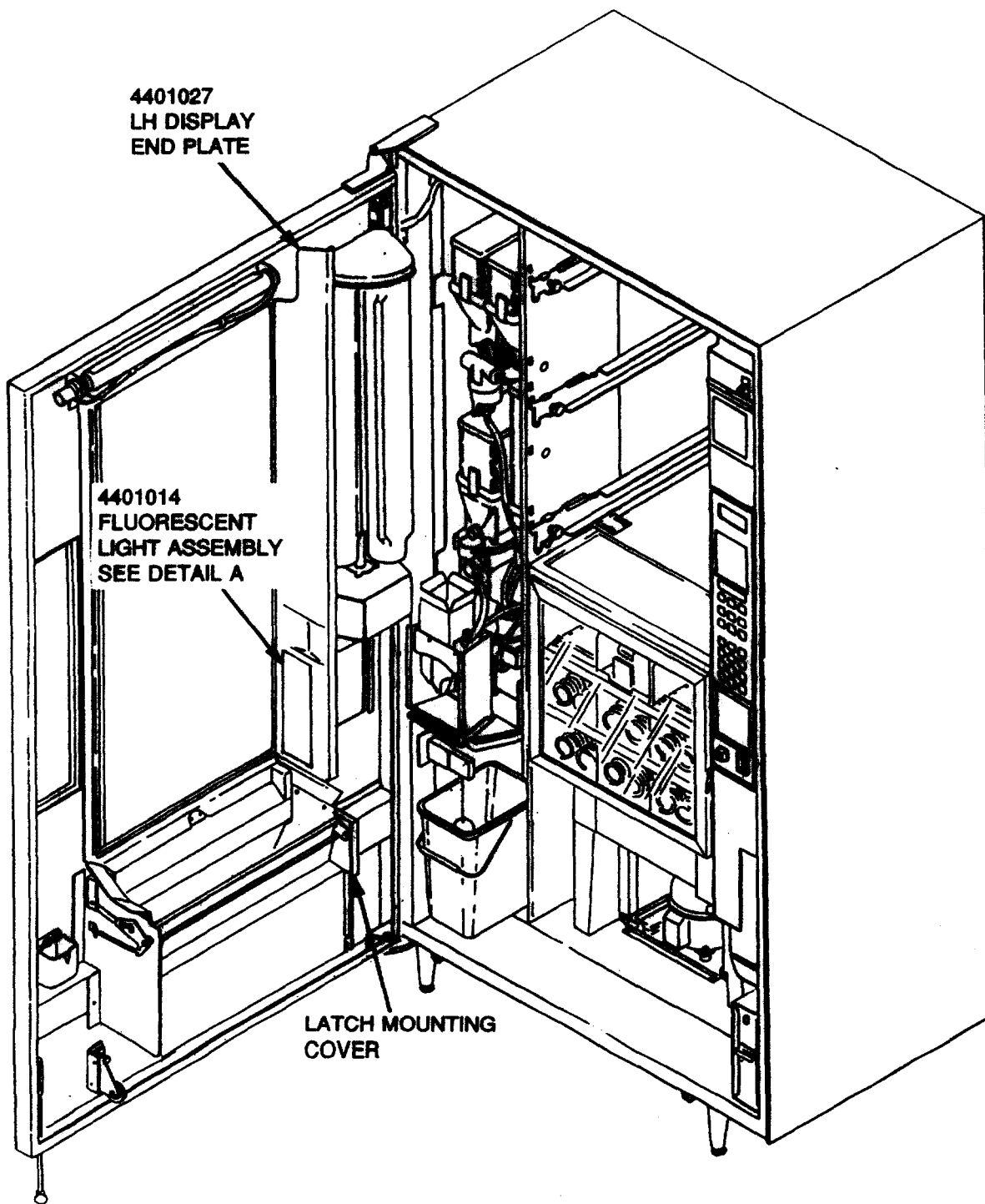
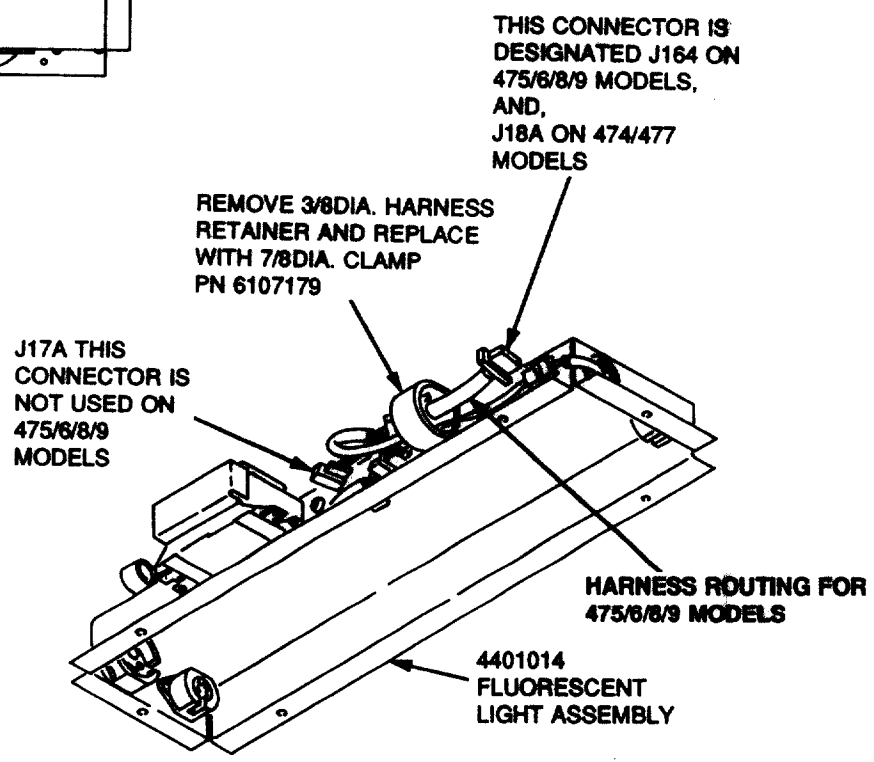
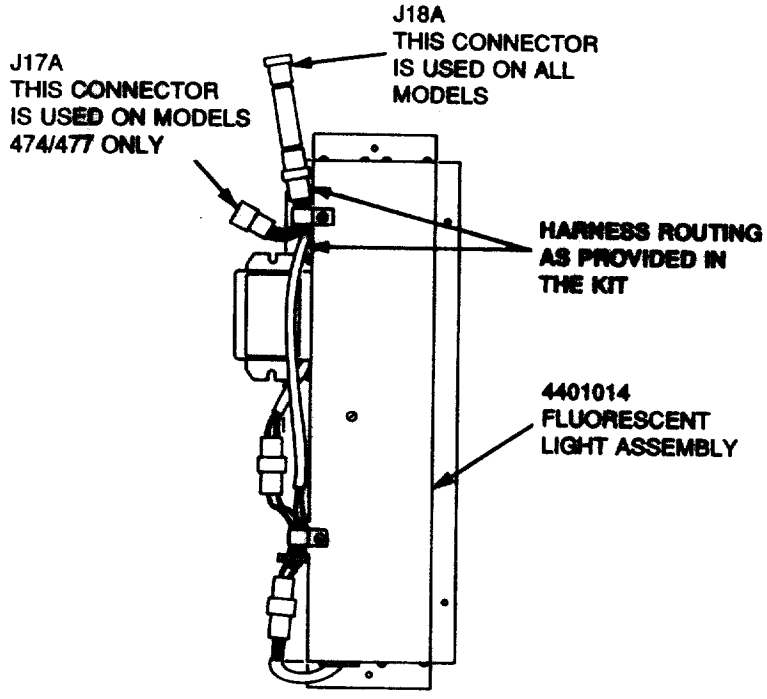

FIGURE 7.



475/476/478/479 MERCHANDISERS SHOWN

FIGURE 8. SHEET 1 of 2



DETAIL A

FIGURE 8. SHEET 2 of 2

**INTERLOCK
SWITCH
(DOMESTIC FROZEN
FOOD MERCHANDISERS
ONLY)**

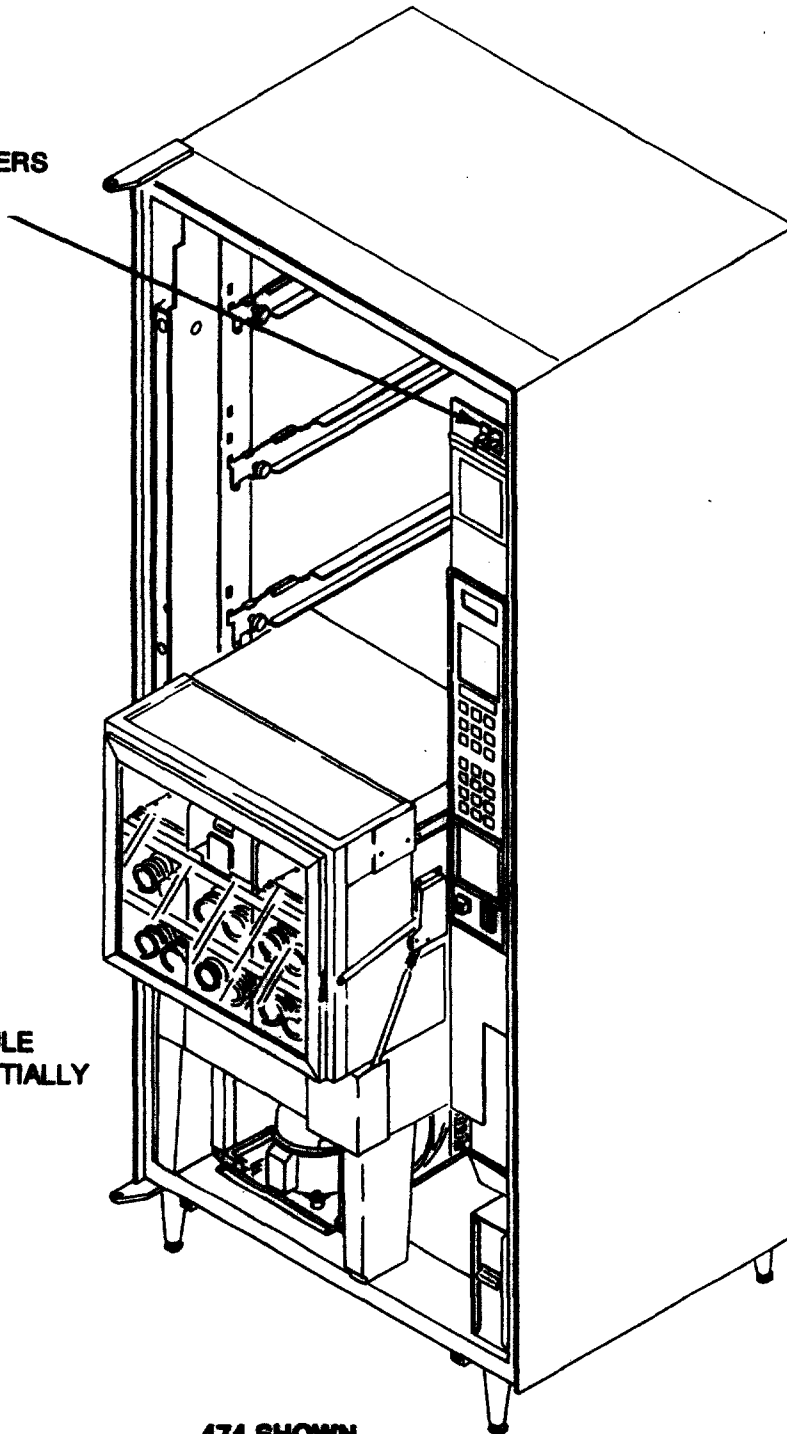

**FOOD MODULE
SHOWN PARTIALLY
INSTALLED**

474 SHOWN

FIGURE 9.

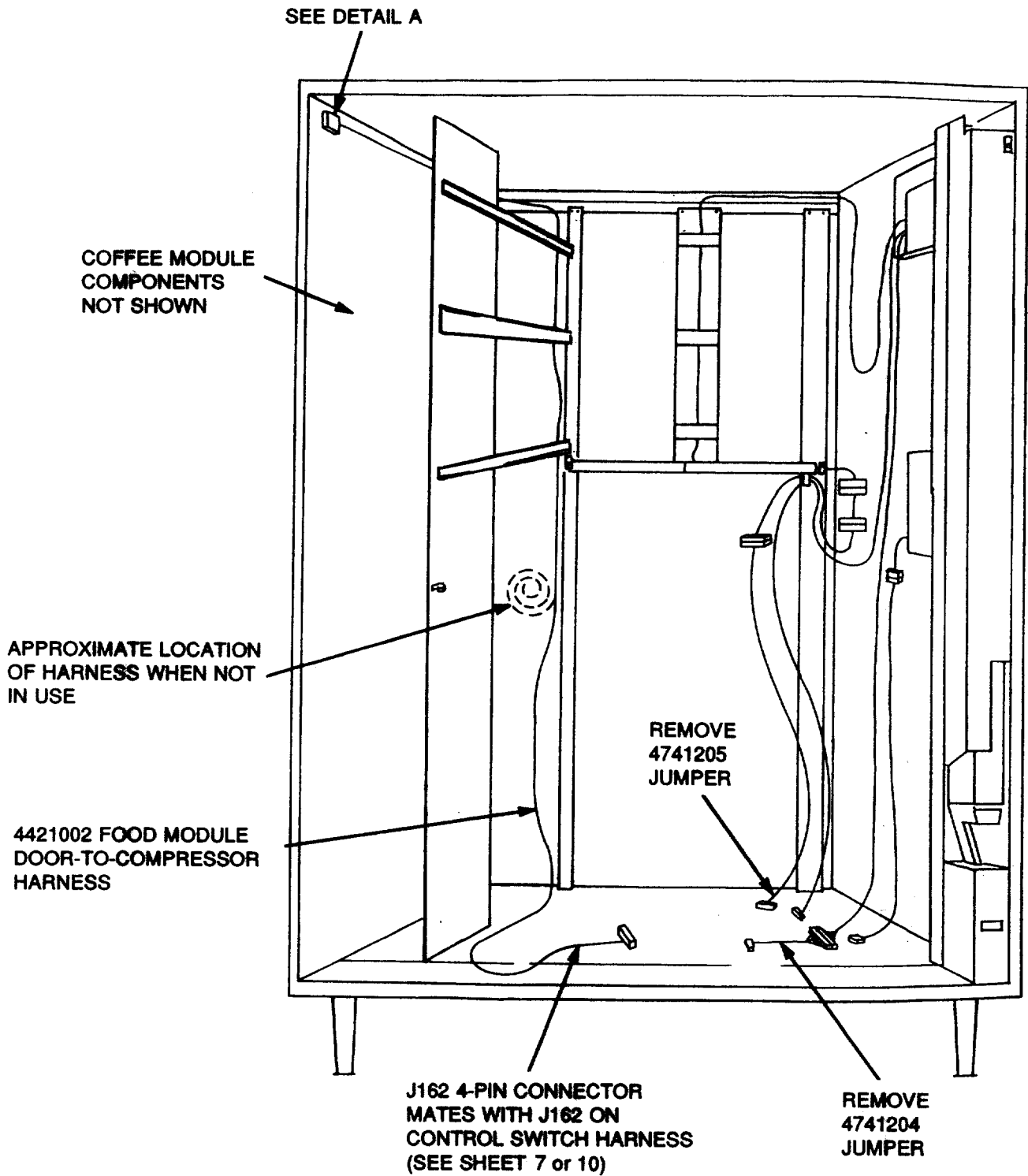

475/476/478/479 SHOWN

FIGURE 10. SHEET 1 of 11

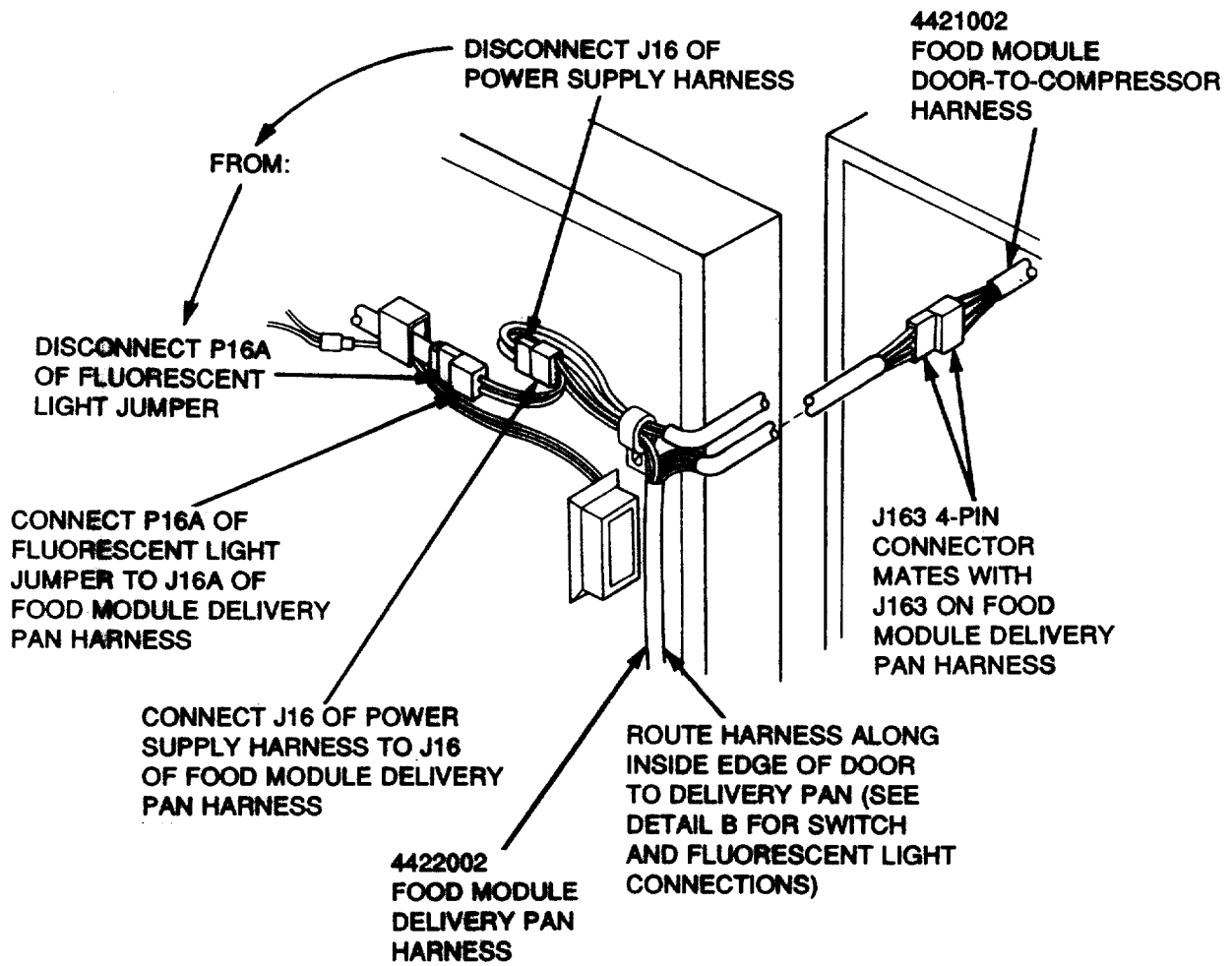

DETAIL A

FIGURE 10. SHEET 2 of 11

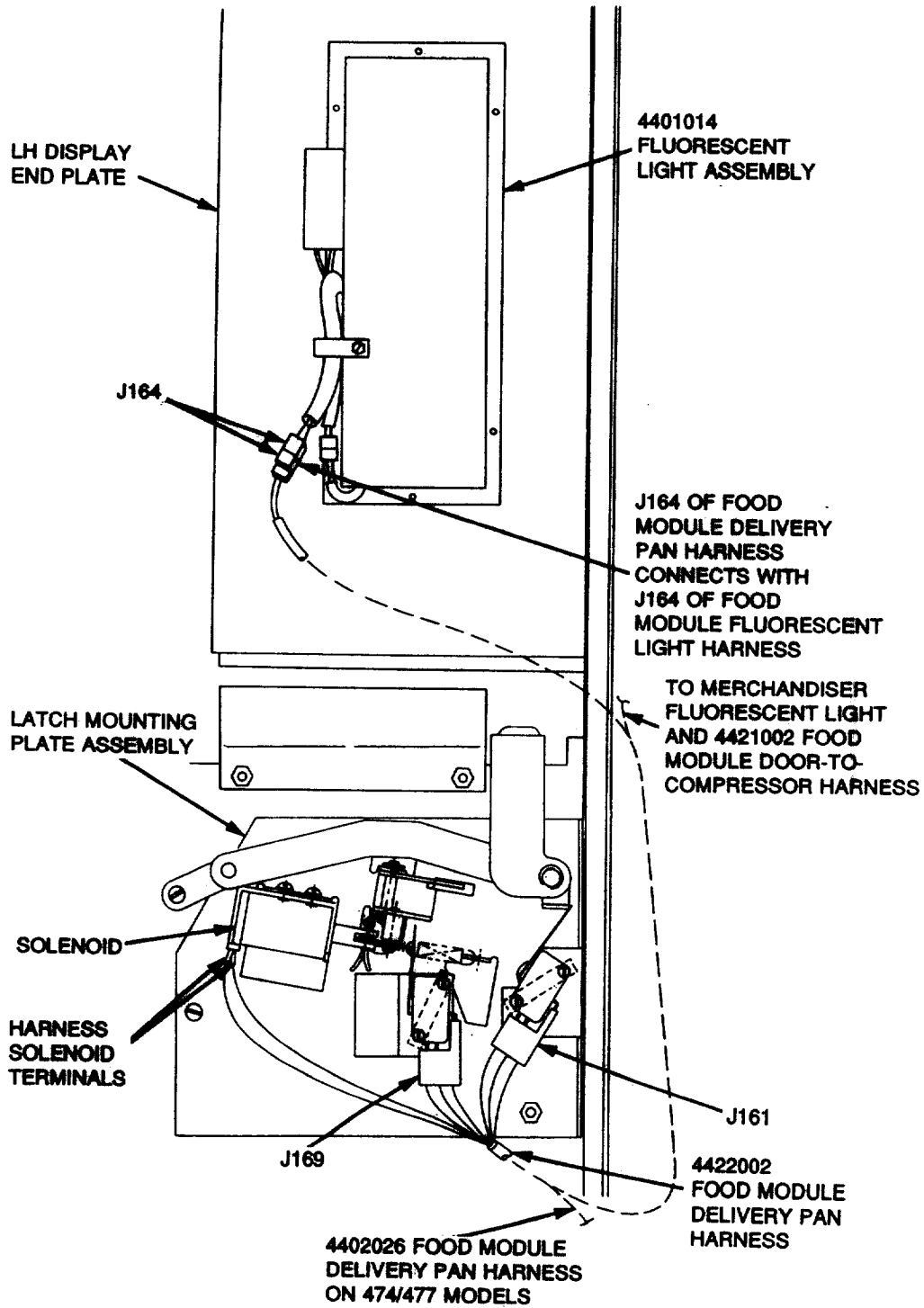

DETAIL B

475/476/478/479 SHOWN

FIGURE 10. SHEET 3 of 11

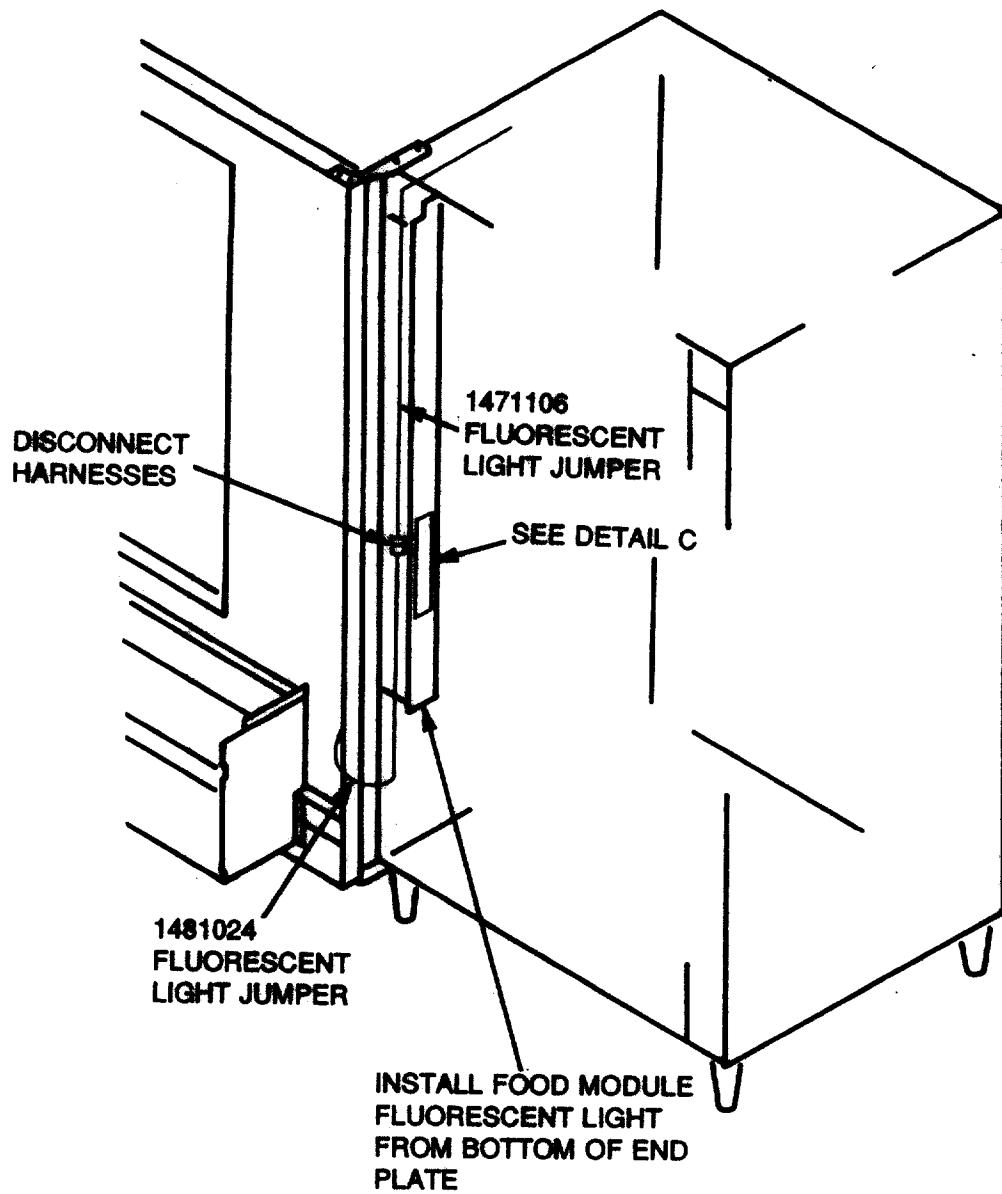

**474/477 MERCHANDISER
FLUORESCENT LIGHT INSTALLATION**

FIGURE 10. SHEET 4 of 11

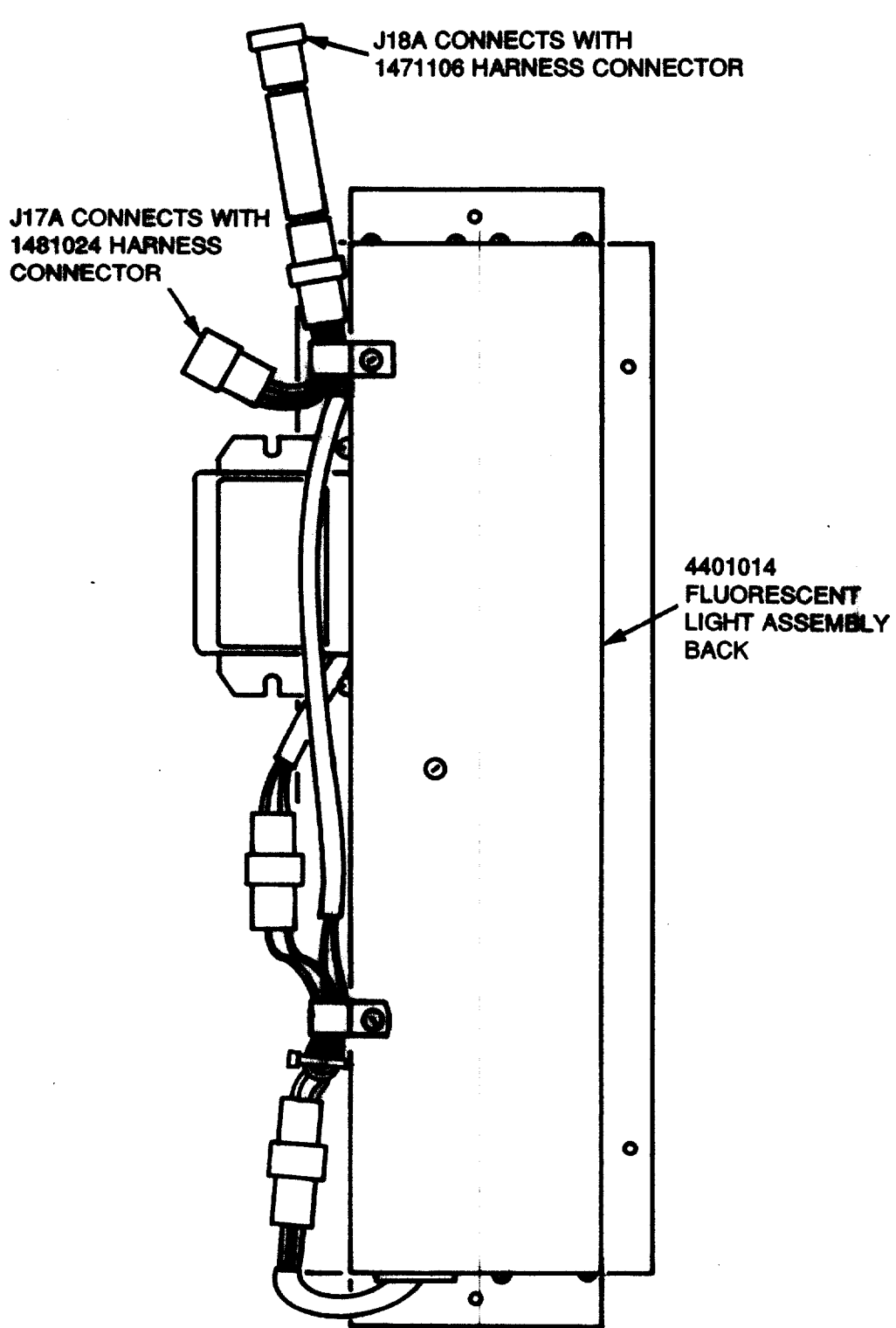

DETAIL C

FIGURE 10. SHEET 5 of 11

475/476/478/479 MODELS

FOOD MODULE
DOOR-TO-COMPRESSOR
HARNESS ROUTING FOR
475/476/478/479 ONLY

J162 4-PIN
CONNECTOR MATES
WITH J162 ON
CONTROL SWITCH
HARNESS (SEE
SHEET 7)

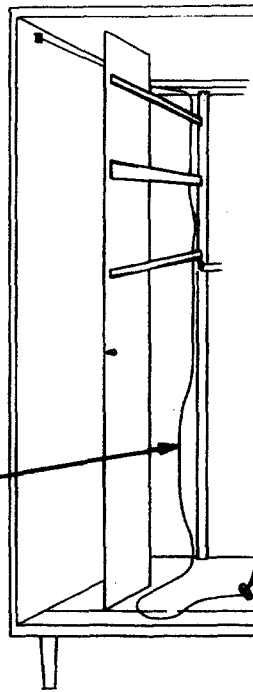

1471183
6-TRAY CABINET
HARNESS

J49 12-PIN
CONNECTOR
MATES WITH
J49 ON FOOD
MODULE (SEE
SHEET 7)

J90 4-PIN
CONNECTOR
MATES WITH
J90 ON FOOD
MODULE PCB
(SEE SHEET 7)

J162 4-PIN
CONNECTOR MATES
WITH J162 ON
CONTROL SWITCH
HARNESS (SEE
SHEET 7)

FOOD MODULE DELIVERY
PAN HARNESS (SEE DETAIL B,
SHEET 3)

CONTROLLER

4401020
FOOD MODULE
TEMPERATURE
SENSOR HARNESS

POWER PANEL

4401030
FOOD MODULE
TRAY JUMPER
HARNESS

J31 12-PIN
INLINE CONNECTOR
MATES WITH J31 ON
FOOD MODULE PCB
(SEE SHEET 7)

J88 2-PIN
CONNECTOR
MATES WITH
J88 ON
COMPRESSOR
HARNESS (SEE
SHEET 7)

CLAMP

474 SHOWN 475/476 SIMILAR

**REFRIGERATED FOOD MODULE CABLE CONNECTIONS
(U.S. ONLY)**

FIGURE 10. SHEET 6 of 11

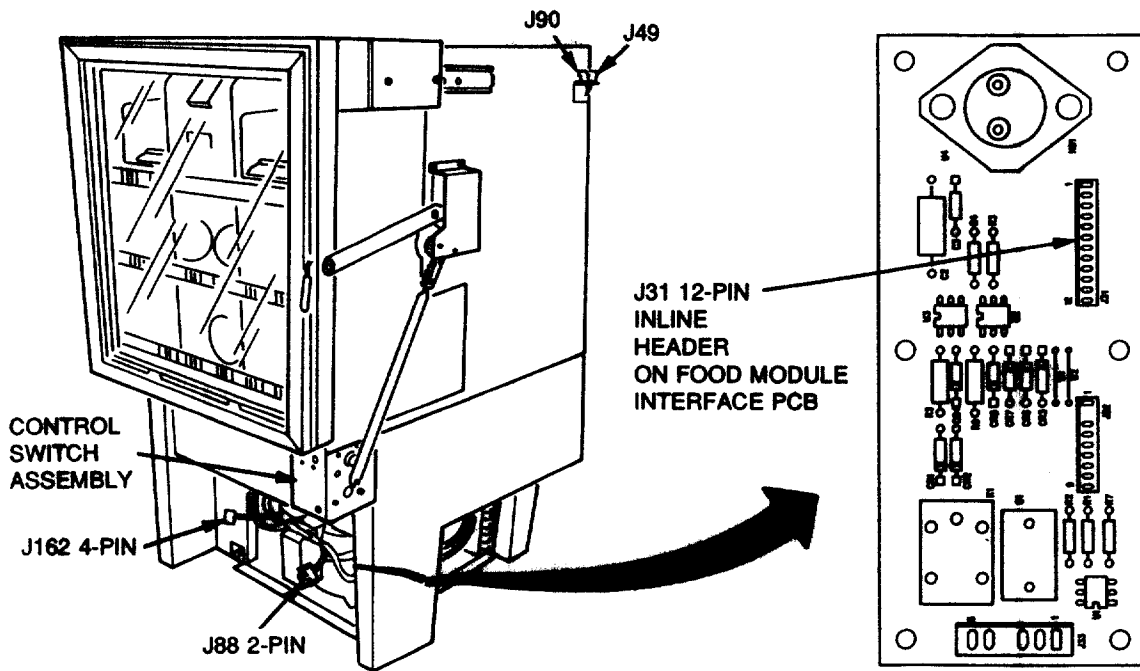

**REFRIGERATED FOOD MODULE
(U.S. ONLY)**

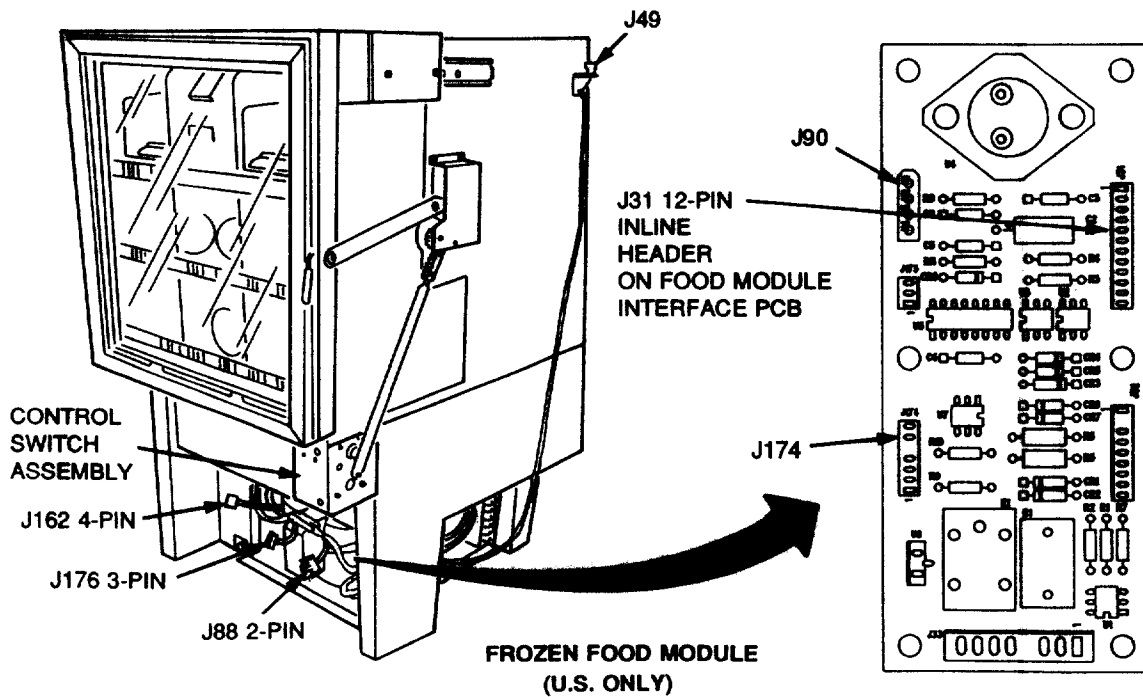

**FROZEN FOOD MODULE
(U.S. ONLY)**

FIGURE 10. SHEET 7 of 11

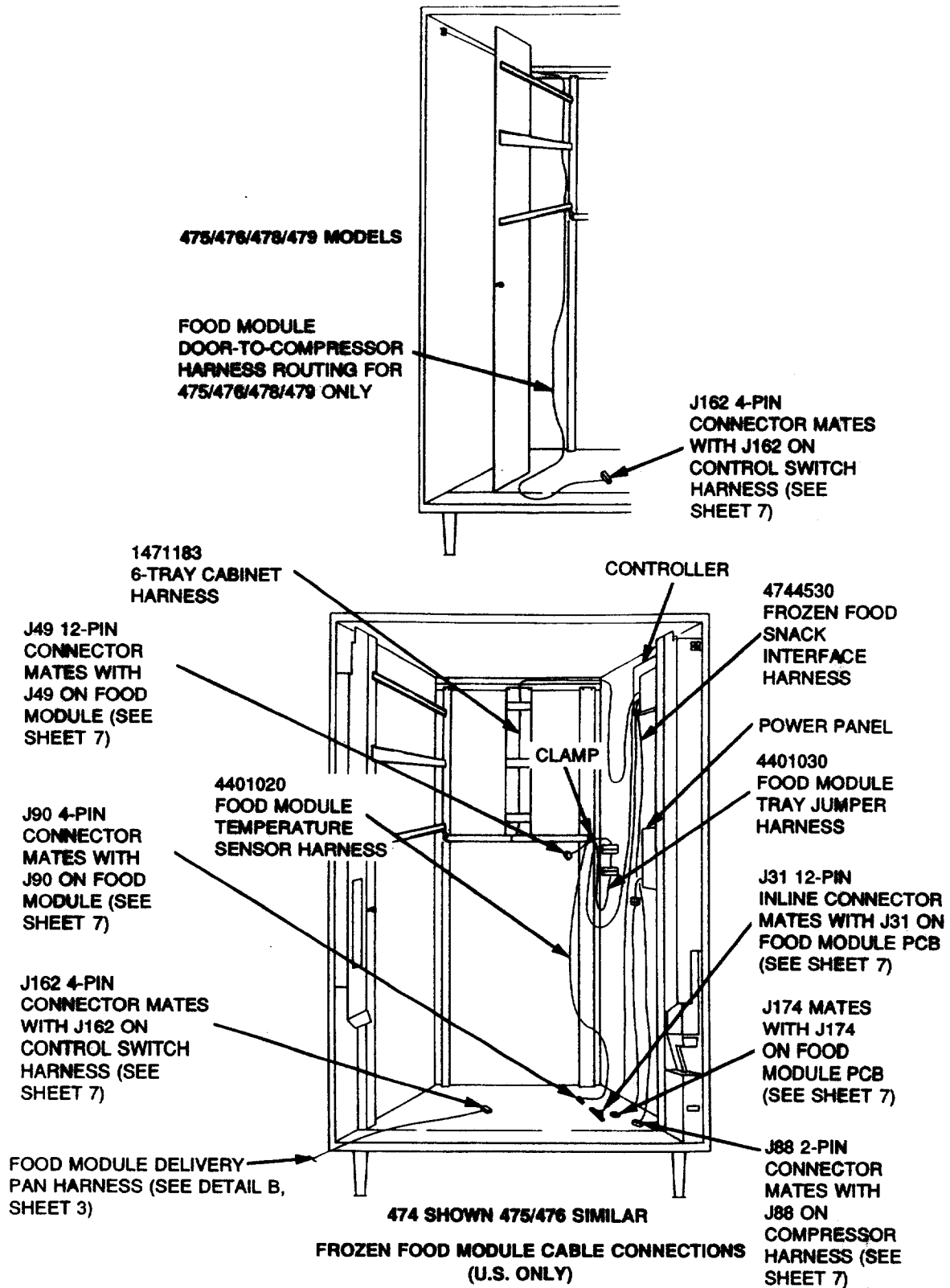

FIGURE 10. SHEET 8 of 11

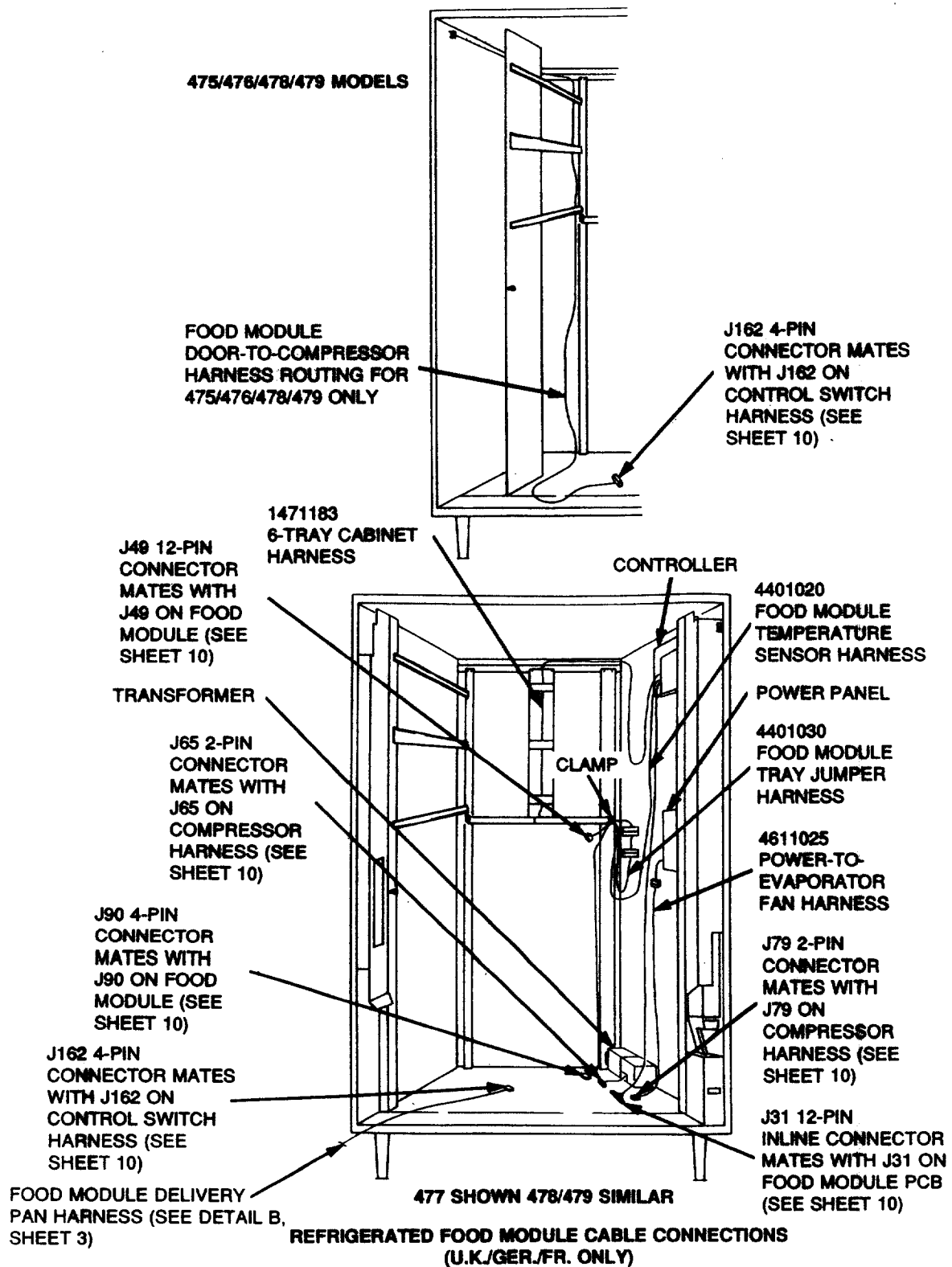

FIGURE 10. SHEET 9 of 11

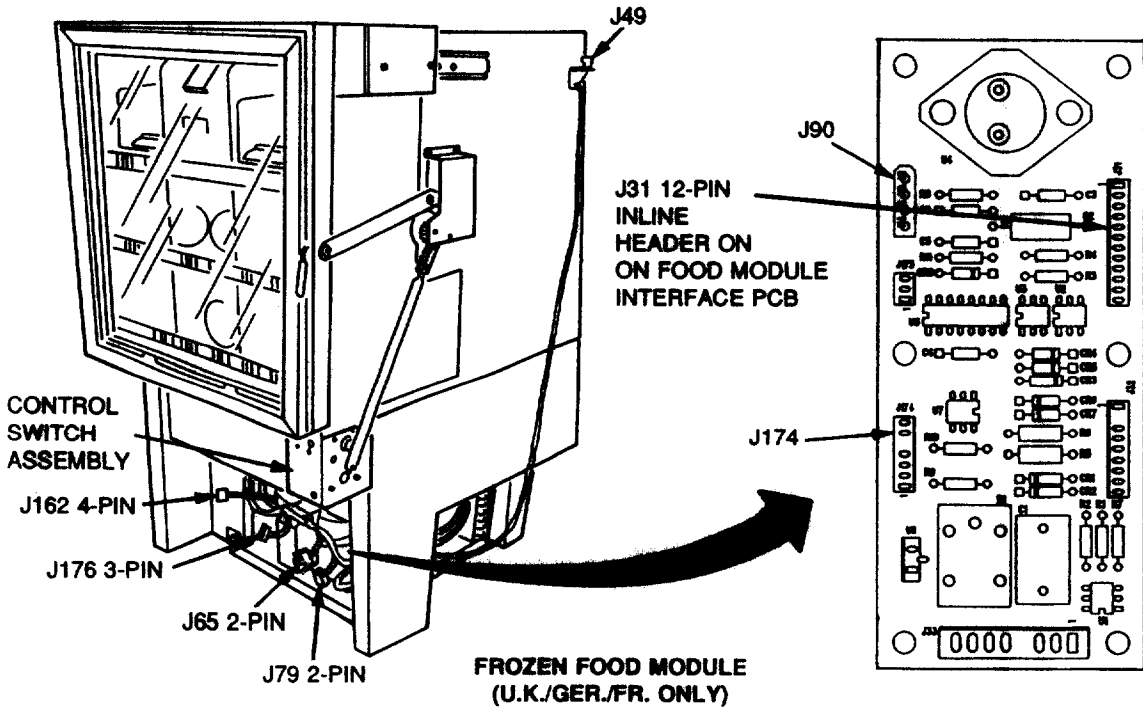
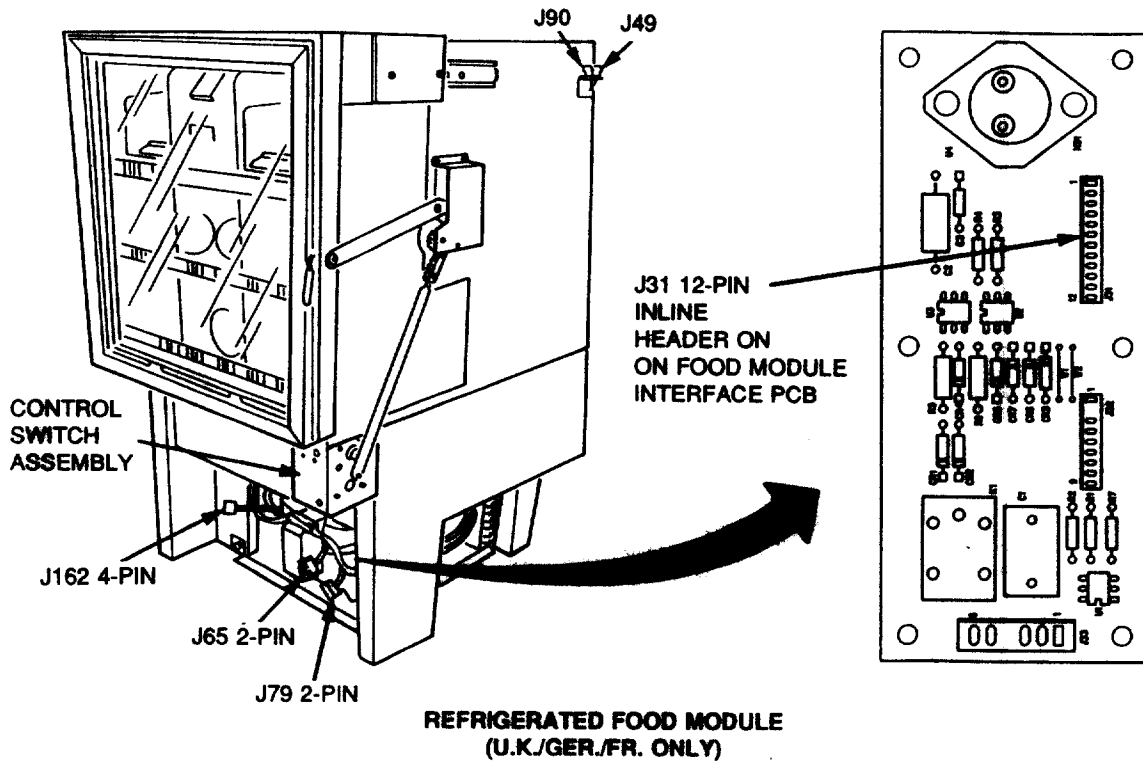

FIGURE 10. SHEET 10 of 11

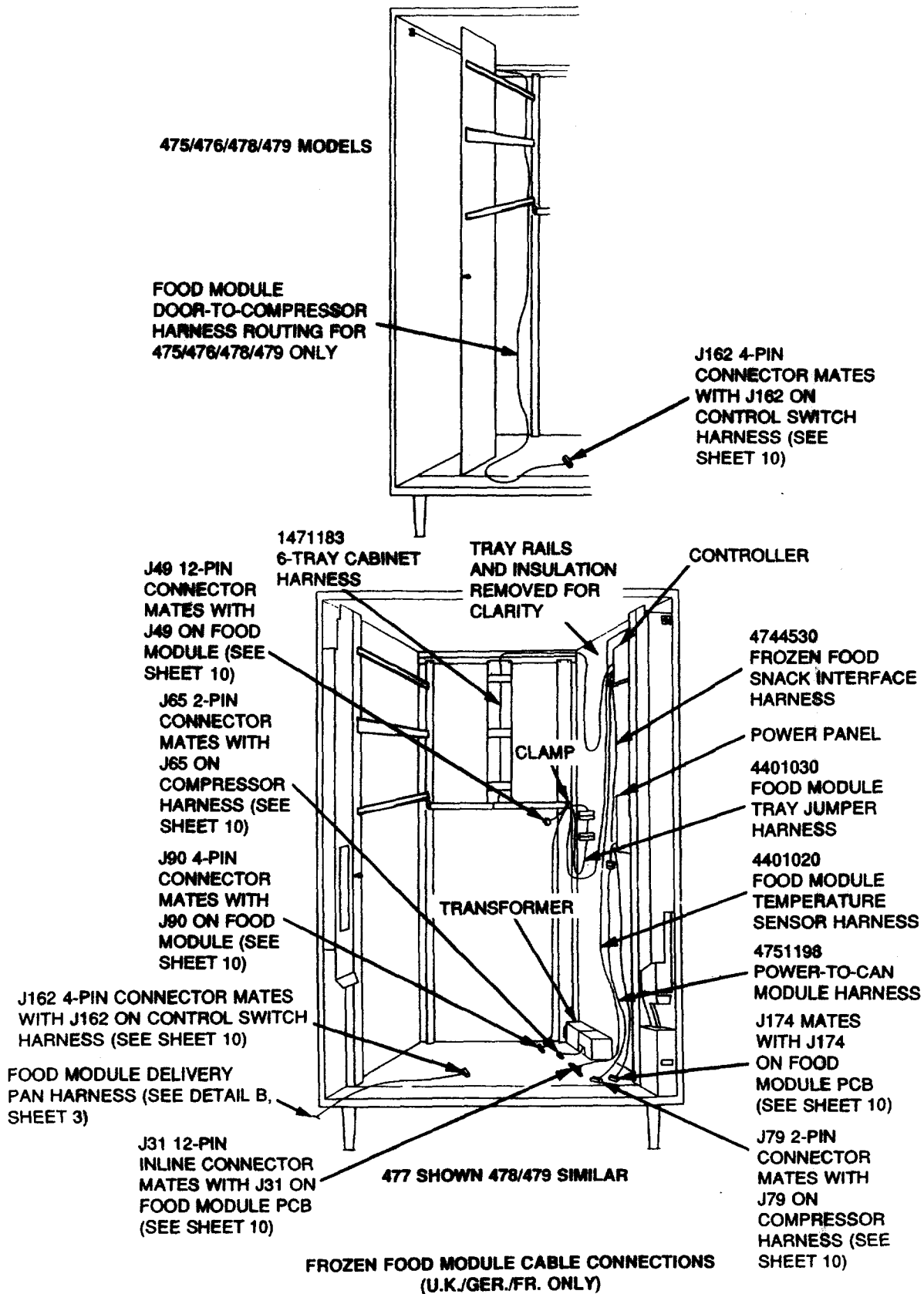

FIGURE 10. SHEET 11 of 11

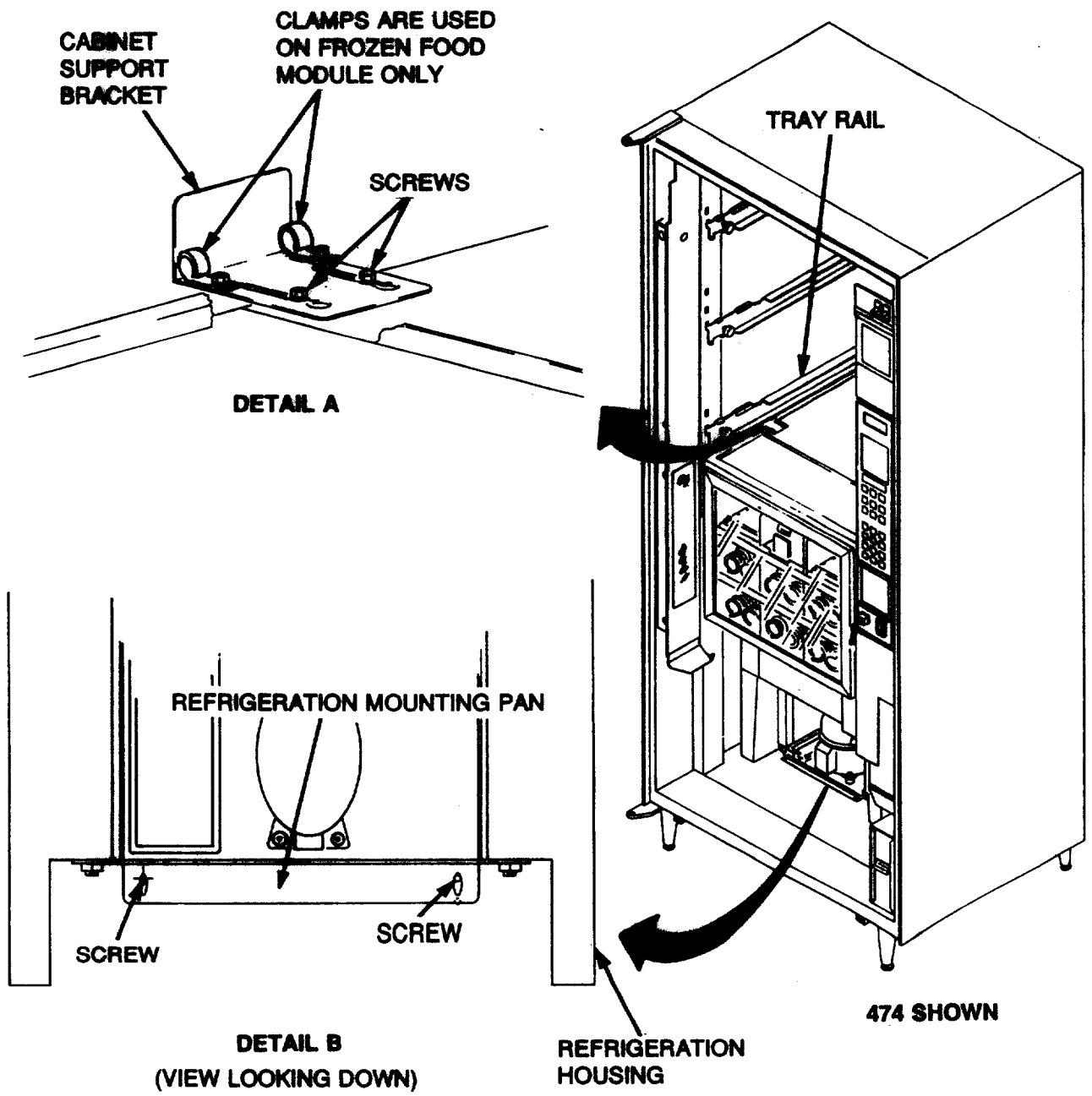

FIGURE 11.

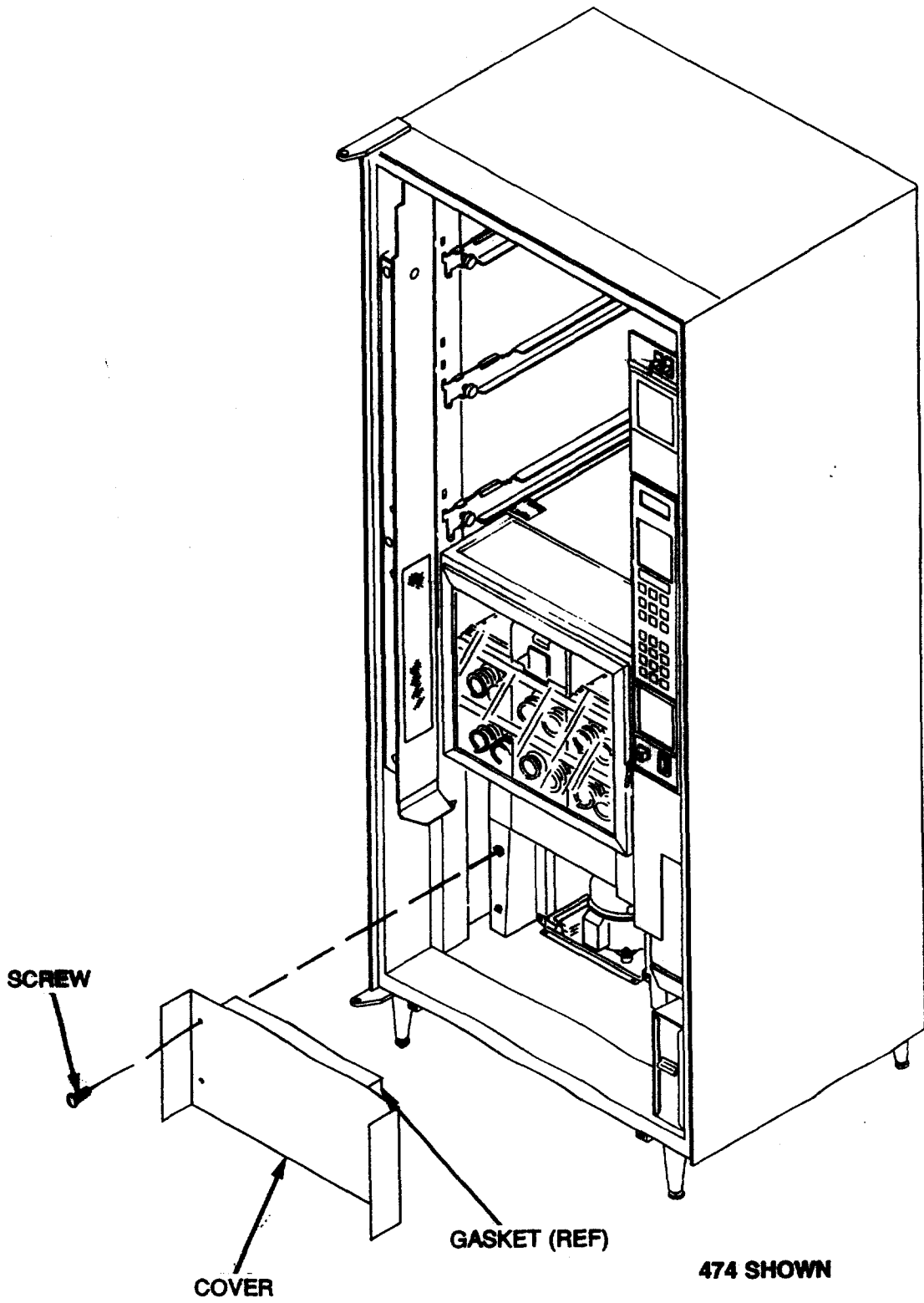

FIGURE 12.

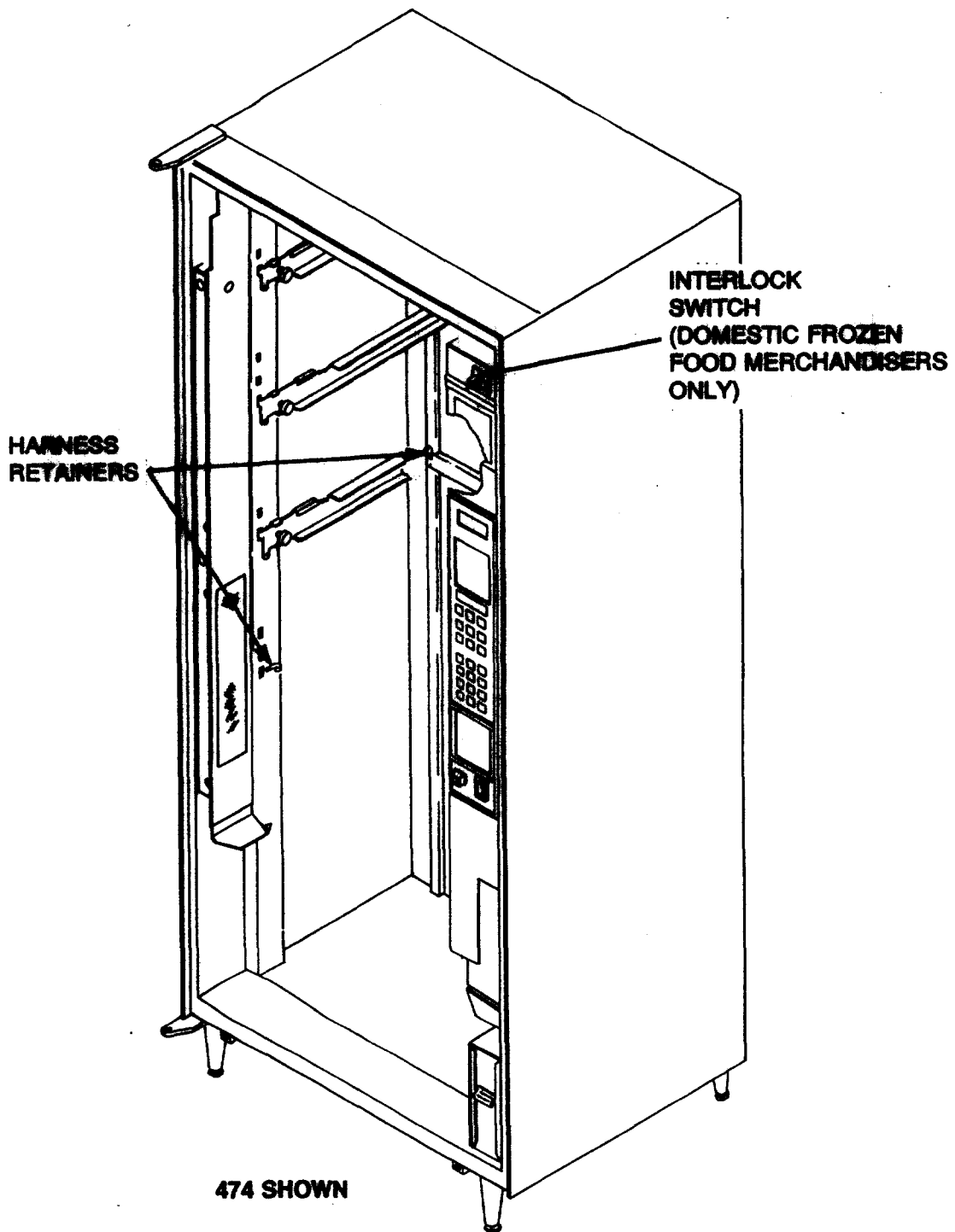

FIGURE 13.

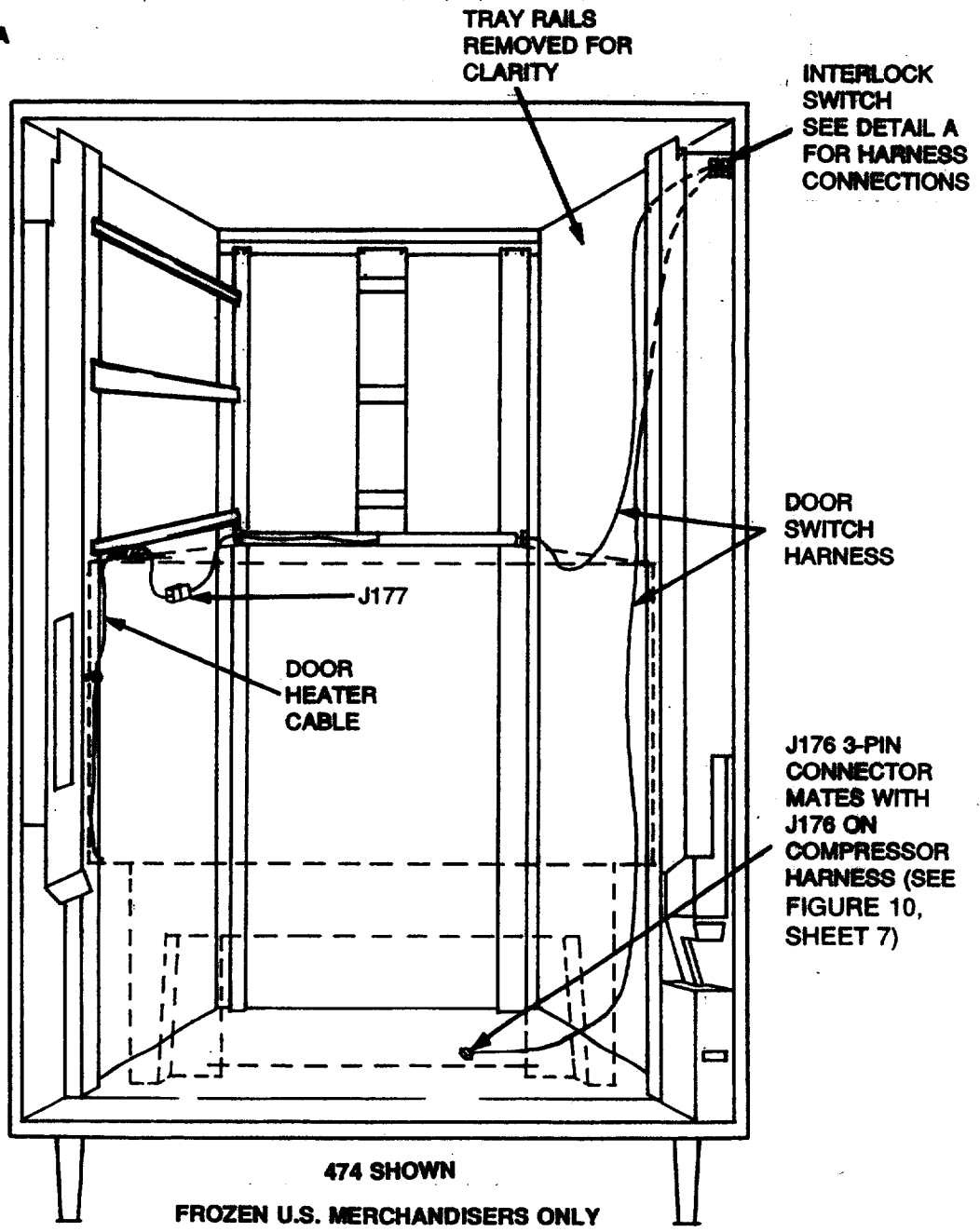
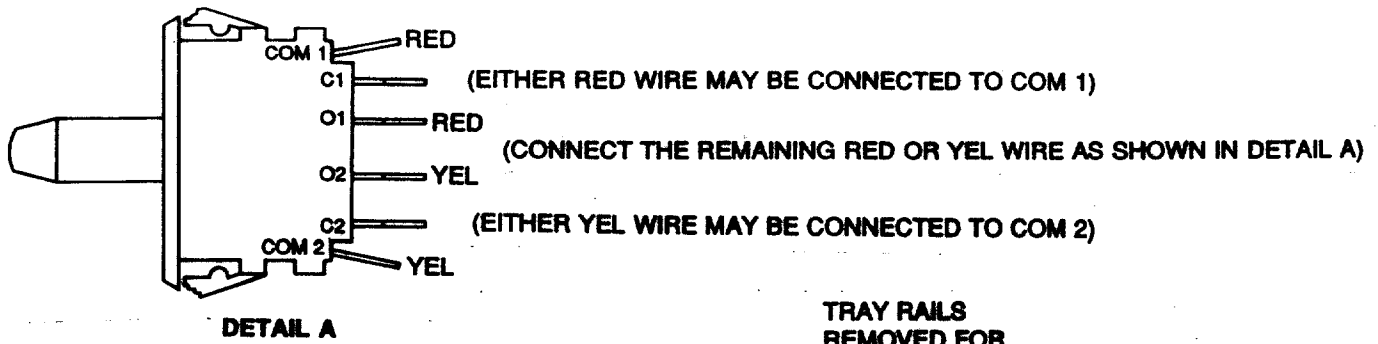
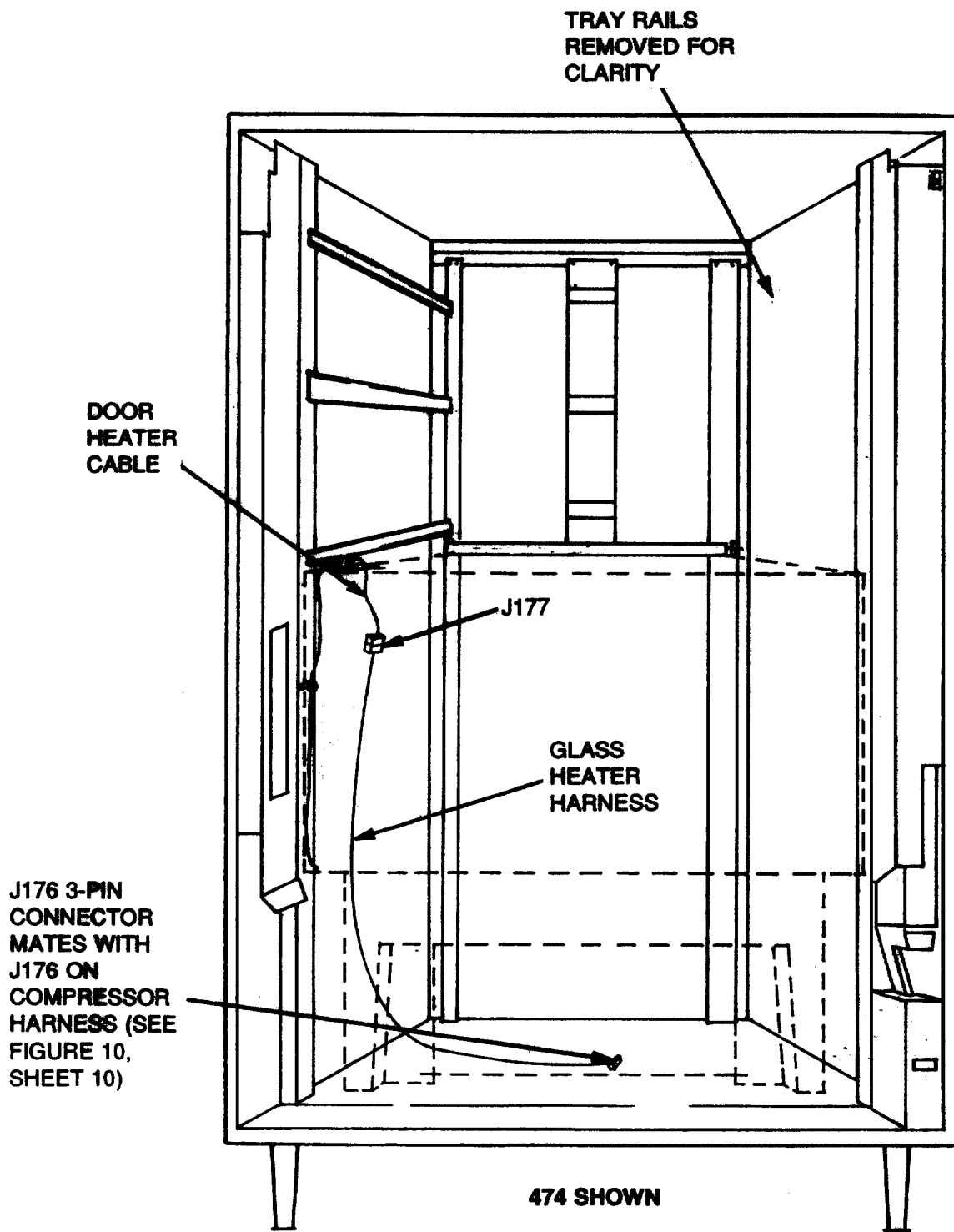

FIGURE 14. SHEET 1 of 2



FROZEN U.K./GER./FR. MERCHANDISERS ONLY

FIGURE 14. SHEET 2 of 2